

Complementary High Density Trench MOSFET

PRODUCT SUMMARY (N-Channel)		
V _{DSS}	I _D	R _{DS(on)} (m-ohm) Max
30V	6.5A	28 @ V _{GS} = 10 V, I _D =6.5A
		42 @ V _{GS} = 4.5V, I _D =5.0A

PRODUCT SUMMARY (P-Channel)		
V _{DSS}	I _D	R _{DS(on)} (m-ohm) Max
-30V	-5A	60 @ V _{GS} = -10V, I _D =-5A
		90 @ V _{GS} = -4.5V, I _D =-4A

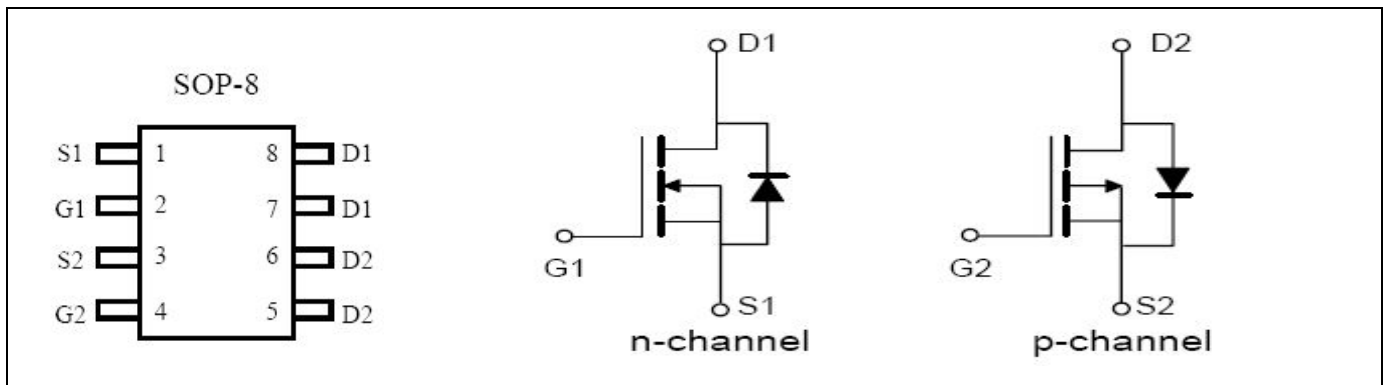

Absolute Maximum Ratings (T_A=25°C, unless otherwise noted)

Symbol	Parameter	N-Channel	P-Channel	Units
V _{DS}	Drain-Source Voltage	30	-30	V
V _{GS}	Gate-Source Voltage	±20	±20	V
I _D	Drain Current ^a	6.5	-5	A
I _{DM}	Drain Current ^b (Pulsed) ^{*1}	28	-20	A
P _D	Total Power Dissipation ^a @ T _A =25°C	2.0	2.0	W
	Total Power Dissipation ^a @ T _A =75°C	1.2	1.2	
T _j , T _{stg}	Operating Junction and Storage Temperature Range ^a	-55 to +150	-55 to +150	°C
R _{θJA}	Thermal Resistance Junction to Ambient ^a	63.2	63.2	°C/W

a: Surface Mounted on FR4 Board , t ≤ 5sec .

b: Pulse width limited by maximum junction temperature.

**N-Channel Electrical Characteristics**($T_A=25^\circ\text{C}$, unless otherwise noted)

Symbol	Characteristic	Test Conditions	Min.	Typ.	Max.	Unit
• Off Characteristics						
BV_{DSS}	Drain-Source Breakdown Voltage	$V_{GS}=0V, I_D=250\mu A$	30	-	-	V
I_{DSS}	Zero Gate Voltage Drain Current	$V_{DS}=24V, V_{GS}=0V$	-	-	-1	μA
I_{GSS}	Gate-Body Leakage Current	$V_{GS}=\pm 20V, V_{DS}=0V$	-	-	± 100	nA
• On Characteristics^c						
$V_{GS(th)}$	Gate Threshold Voltage	$V_{DS}=V_{GS}, I_D=250\mu A$	1.0	1.4	3.0	V
$R_{DS(on)}$	Drain-Source On-State Resistance	$V_{GS}=10V, I_D=6.5A$	-	22	28	m Ω
		$V_{GS}=4.5V, I_D=5.0A$	-	34	42	
gfs	Forward Transconductance	$V_{DS}=5V, I_D=5.0A$	-	6.0	-	S
• Dynamic Characteristics^d						
C_{iss}	Input Capacitance	$V_{DS}=15V, V_{GS}=0V, f=1MHz$	-	398	-	pF
C_{oss}	Output Capacitance		-	67	-	
C_{rss}	Reverse Transfer Capacitance		-	61	-	
• Switching Characteristics^d						
Q_g	Total Gate Charge	$V_{DS}=10V, I_D=1A, V_{GS}=10V$	-	7.4	-	nC
Q_{gs}	Gate-Source Charge		-	1.7	-	
Q_{gd}	Gate-Drain Charge		-	1.3	-	
$t_{d(on)}$	Turn-on Delay Time	$V_{DD}=15V, R_L=15\Omega, I_D=1A,$ $V_{GEN}=10V, R_G=6\Omega$	-	8.0	-	nS
t_r	Turn-on Rise Time		-	11.2	-	
$t_{d(off)}$	Turn-off Delay Time		-	17.2	-	
t_f	Turn-off Fall Time		-	7.54	-	
• Drain-Source Diode Characteristics						
V_{SD}	Drain-Source Diode Forward Voltage	$V_{GS}=0V, I_S=2.5A$	-	-	1.3	V

Note:

b: Pulse width limited by maximum junction temperature.

c: Guaranteed by design, not subject to production testing.

**P-Channel Electrical Characteristics** ($T_A=25^\circ\text{C}$, unless otherwise noted)

Symbol	Characteristic	Test Conditions	Min.	Typ.	Max.	Unit
• Off Characteristics						
BV_{DSS}	Drain-Source Breakdown Voltage	$V_{GS}=0V, I_D=-250\mu A$	-30	-	-	V
I_{DSS}	Zero Gate Voltage Drain Current	$V_{DS}=-24V, V_{GS}=0V$	-	-	-1	μA
I_{GSS}	Gate-Body Leakage Current	$V_{GS}=\pm 20V, V_{DS}=0V$	-	-	± 100	nA
• On Characteristics^c						
$V_{GS(th)}$	Gate Threshold Voltage	$V_{DS}=V_{GS}, I_D=-250\mu A$	-1.0	-	-3.0	V
$R_{DS(on)}$	Drain-Source On-State Resistance	$V_{GS}=-10V, I_D=-5A$	-	-	60	m Ω
		$V_{GS}=-4.5V, I_D=-4A$	-	-	90	
gfs	Forward Transconductance	$V_{DS}=-5V, I_D=-5A$	-	8.6	-	S
• Dynamic Characteristics^d						
C_{iss}	Input Capacitance	$V_{DS}=-15V, V_{GS}=0V, f=1\text{MHz}$	-	700	-	pF
C_{oss}	Output Capacitance		-	120	-	
C_{rss}	Reverse Transfer Capacitance		-	75	-	
• Switching Characteristics^d						
Q_g	Total Gate Charge	$V_{DS}=-15V, I_D=-5A, V_{GS}=-10V$	-	14.7	-	nC
Q_{gs}	Gate-Source Charge		-	2	-	
Q_{gd}	Gate-Drain Charge		-	3.8	-	
$t_{d(on)}$	Turn-on Delay Time	$V_{DD}=-15V, R_L=3\Omega,$ $V_{GEN}=-10V, R_G=3\Omega$	-	8.3	-	nS
t_r	Turn-on Rise Time		-	5	-	
$t_{d(off)}$	Turn-off Delay Time		-	29	-	
t_f	Turn-off Fall Time		-	14	-	
• Drain-Source Diode Characteristics						
V_{SD}	Drain-Source Diode Forward Voltage	$V_{GS}=0V, I_S=-1A$	-	-	-1.2	V

Note:

b: Pulse width limited by maximum junction temperature.

c: Guaranteed by design , not subject to production testing .

Characteristics Curve(N-Channel)

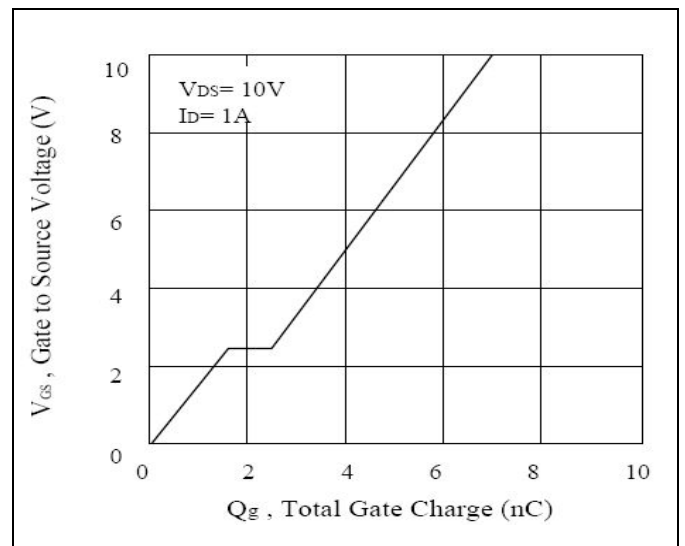
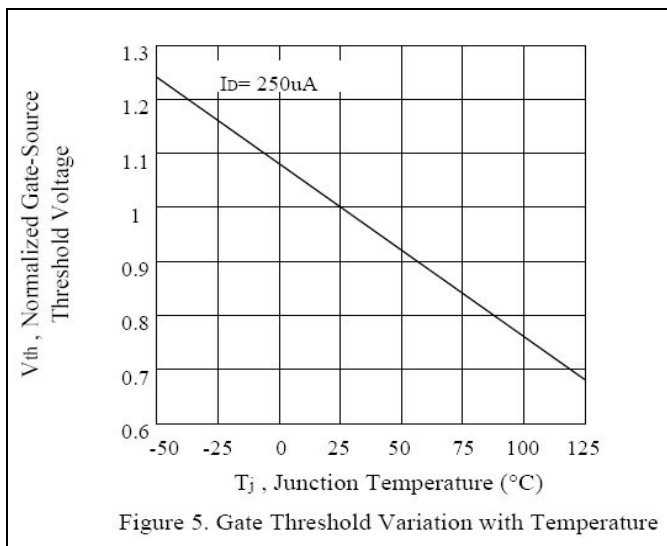
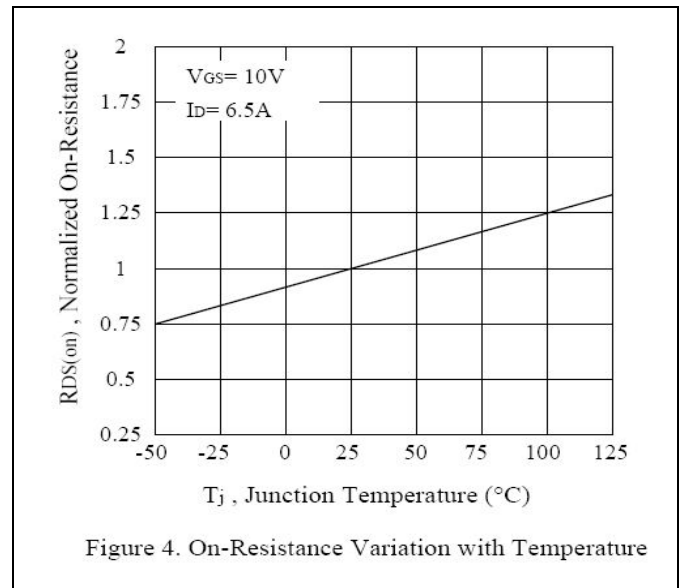
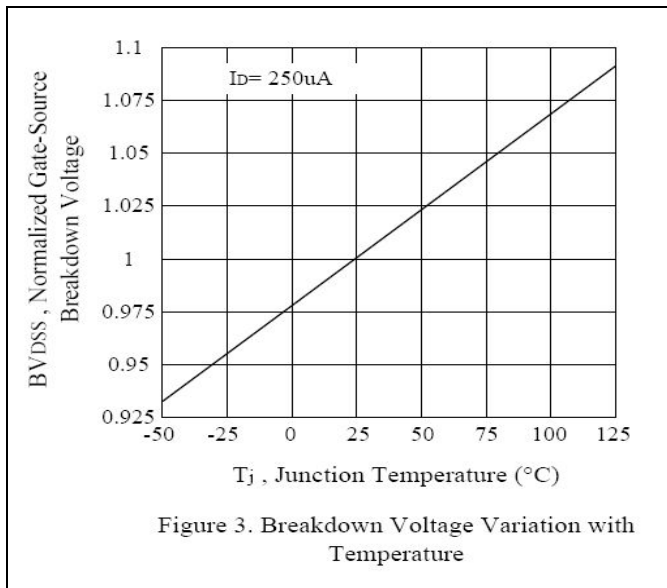
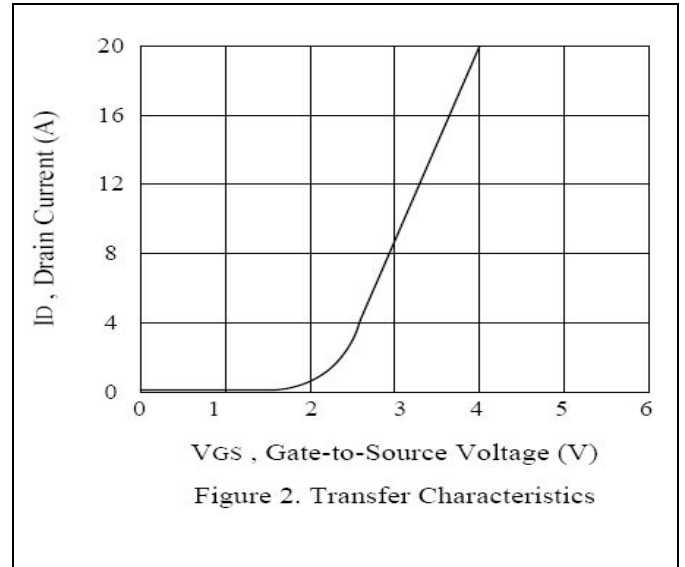
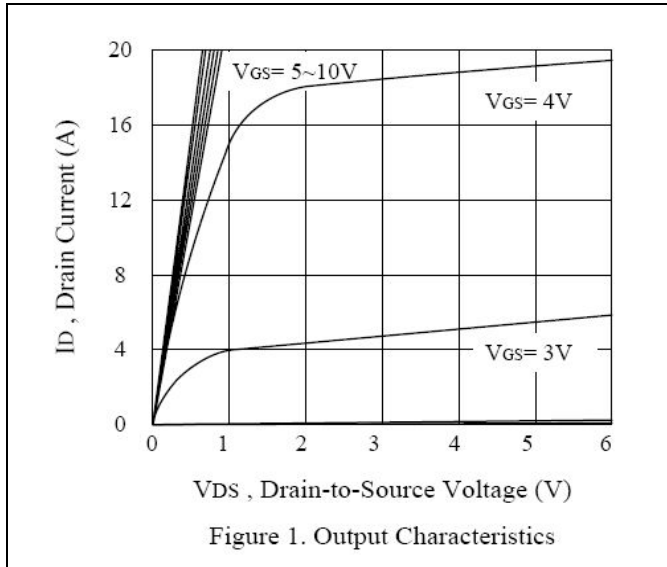

Characteristics Curve(N-Channel)

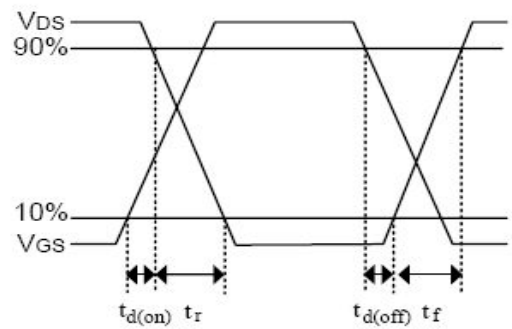
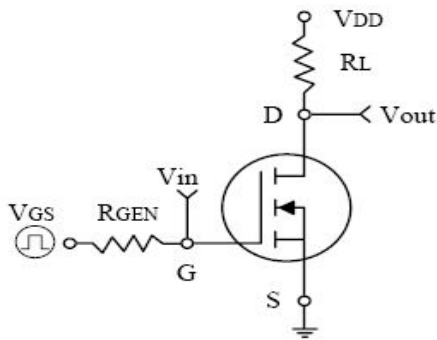
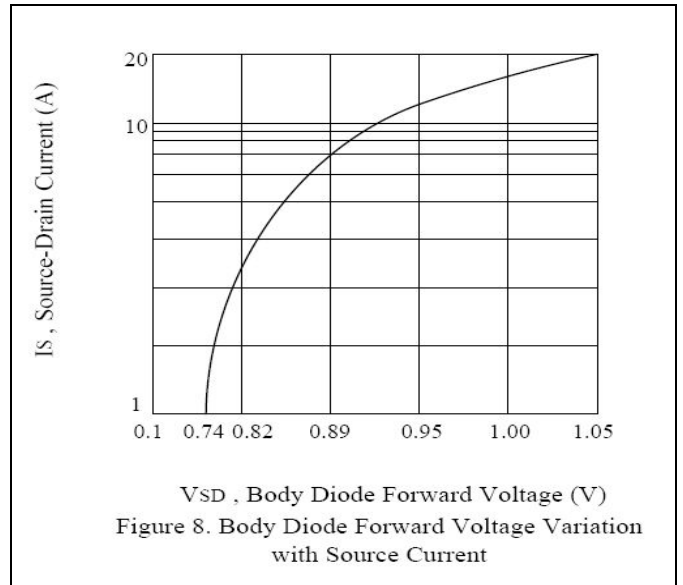
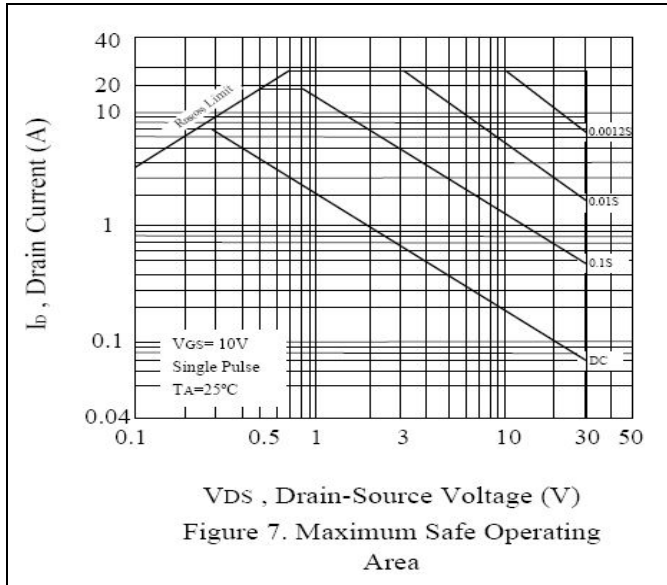
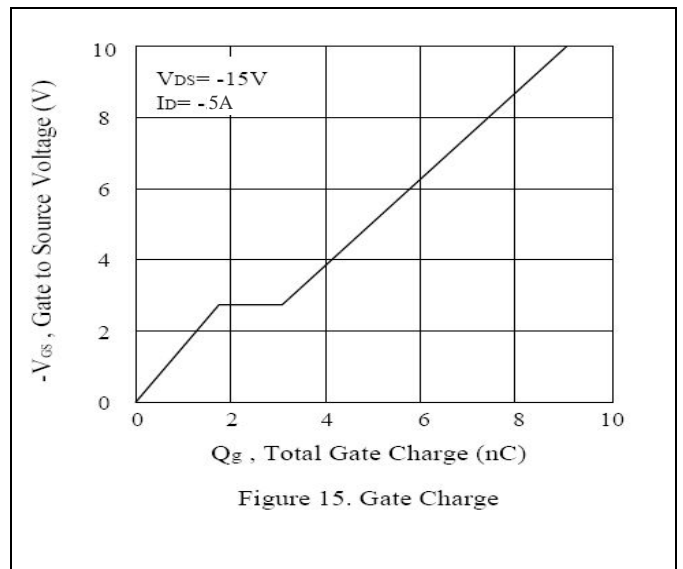
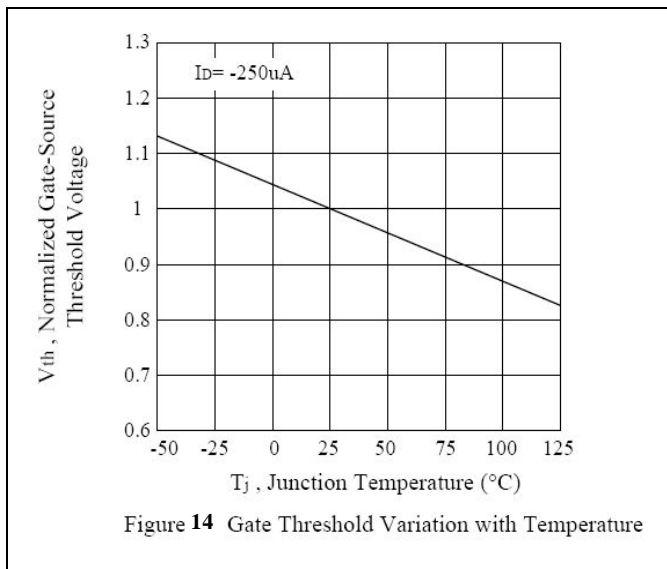
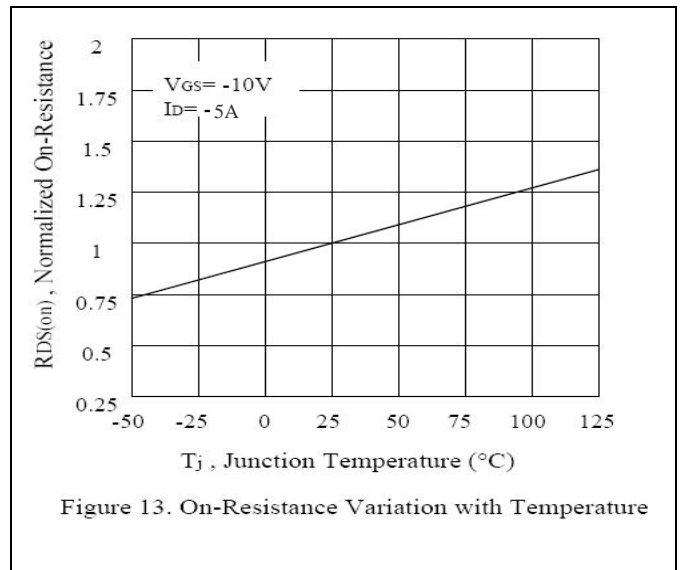
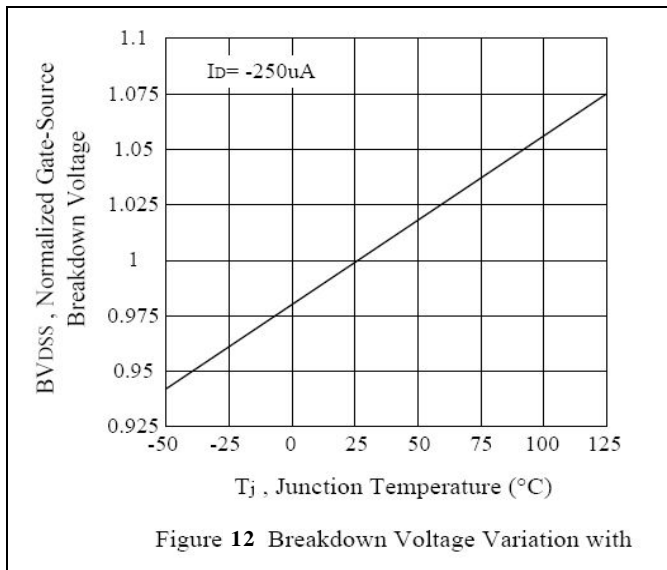
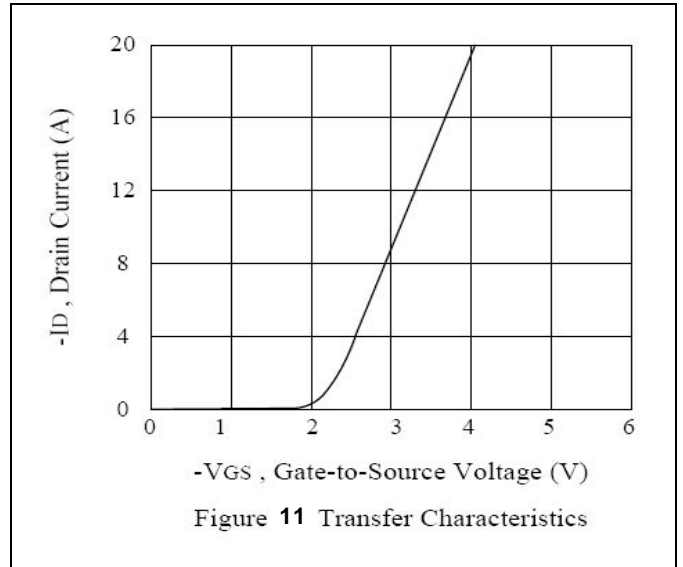
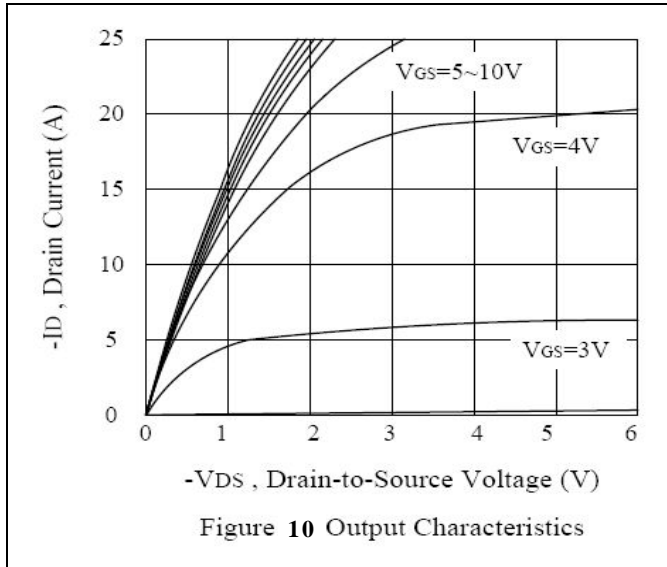

Figure 9. Switching Test Circuit and Switching Waveforms

Characteristics Curve(P-Channel)



Characteristics Curve(P-Channel)

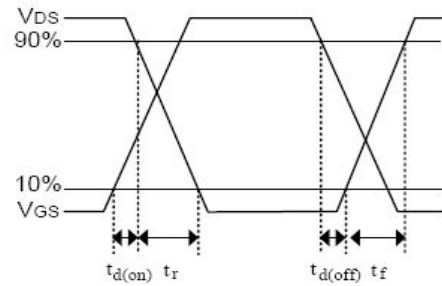
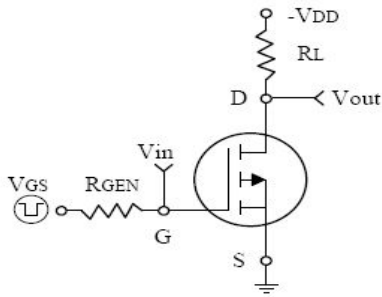
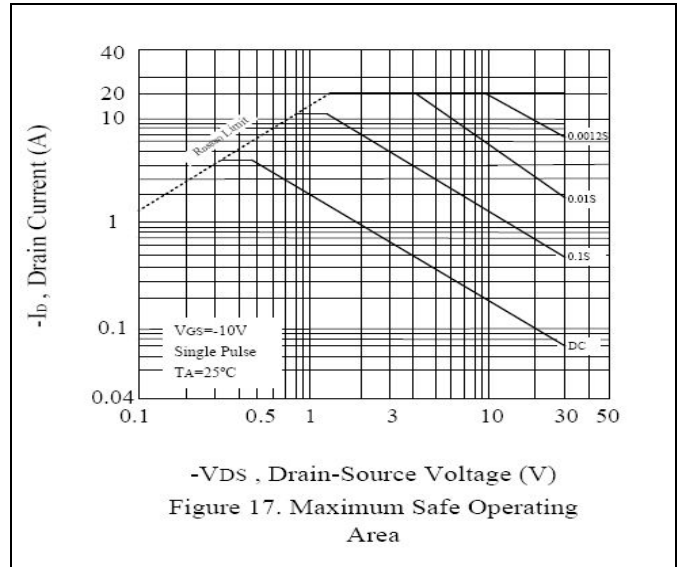
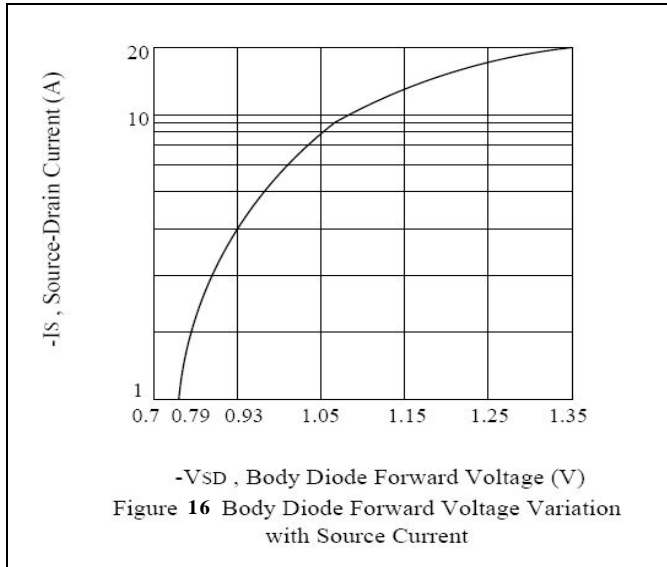

Figure 18 Switching Test Circuit and Switching Waveforms