



General Description

The MC34063 is a monolithic control circuit containing the primary functions required for DC-to-DC converter. The device consists of an internal temperature compensated reference, comparator, controlled duty cycle oscillator with an active current limit circuit, driver and high current output switch. This was specifically designed to be incorporated in Step-up, and Step-down and Voltage-Inverting applications with a minimum number of external components.

Features

- Operation from 3.0V to 35V input
- Low Standby Current
- Current Limiting
- Output Switch Current to 1.5A
- Output Voltage Adjustable
- Frequency Operation to 100KHz
- Precision 2% Reference

Absolute Maximum Ratings

Power Supply Voltage	35V
Comparator Input Voltage Range	-0.3 to +35V
Switch Collector Voltage	35V
Switch Emitter Voltage (V _{pin1} =35V)	35V
Switch Collector to Emitter Voltage	35V
Driver Collector Current	100mA
Switch Current	1.5A

Power Dissipation and Thermal Characteristics

Plastic Package, P Suffix

TA = 25 °C 1.25W

Thermal Resistance 100 °C/W

Operating Junction Temperature +150 °C

Operating Ambient Temperature Range 0 to +70 °C

Storage Temperature Range -65 to +150 °C

Chip Diagrams & Pads Coordinates

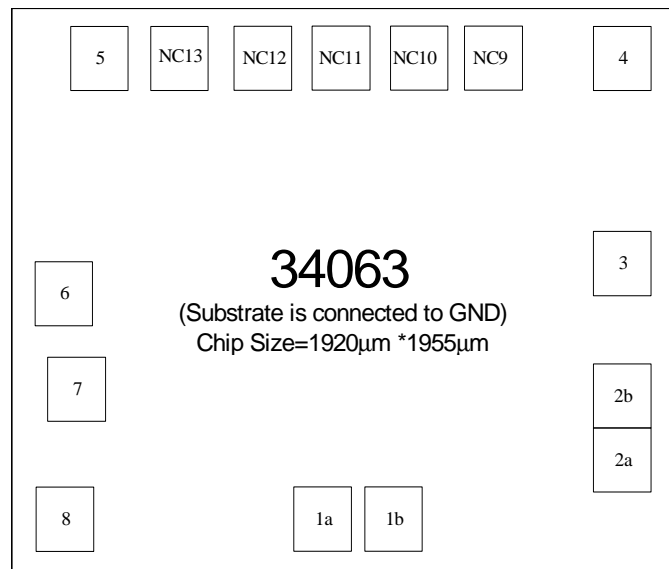

PIN NO	NAME	H3063	
		X(µm)	Y(µm)
1a	SC	1035	228
1b		1209	228
2a	SE	1811	861
2b		1811	1027
3	TC	1786	1276
4	GND	1831	1765
5	CII	364	1821
6	VCC	185	1056
7	IPK	276	690
8	DRIC	275	193
NC9	For Reference	1256	1821
NC10		1098	1821
NC11		940	1821
NC12	Voltage Adjust	782	1821
NC13		588	1821

Electronics Characteristics ($V_{CC}=5V, T_A=25^{\circ}C, C_T=1nF$, unless otherwise specified.)

Characteristics	Symbol	Min.	Typ.	Max.	Unit
-----------------	--------	------	------	------	------

1.25V Reference

Reference Voltage($V_{CC}=5V - 25V$)	Vref	1.225	1.25	1.275	V
--	------	-------	------	-------	---

Comparator

Threshold Voltage	Vth	1.225	1.25	1.275	V
-------------------	-----	-------	------	-------	---

Oscillator

Frequency($V_{pin5}=0V$)	f _{osc}	24	33	42	kHz
Charge Current($V_{CC}=5.0V$ to $35V$)	I _{chg}	24	35	42	µA
Discharge Current($V_{CC}=5.0V$ to $35V$)	I _{dischg}	140	220	260	µA
Discharge to Charge Current Ratio	I _{dischg} /I _{chg}	5.2	6.5	7.5	-
Current Limit Sense Voltage(Pin7 to Vcc)	V _{ipk} (sense)	250	300	350	mV

Output Switch (Low duty cycle pulse techniques are used during test)

Saturation Voltage, Darlington Connection (I _{sw} =1.0A, Pin1,8 connected)	V _{ce} (sat)	-	1.0	1.3	V
Saturation Voltage, Darlington Connection (I _{sw} =1.0A, R _{pin8} =82Ω to V _{cc} , Forced β=20)	V _{ce} (sat)	-	0.45	0.7	V
DC Current Gain(I _{sw} =1.0A), V _{ce} =5.0V)	H _{fe}	50	75	-	-
Collector Off-State Current(V _{ce} =35V)	I _c (off)	-	0.01	100	µA

Total Device

Supply Current($V_{CC}=5$ to $35V, V_{pin7}=V_{CC}, V_{pin5}>V_{th}, Pin2=GND$, the others open)	I _{cc}	-	-	4.0	mA
--	-----------------	---	---	-----	----

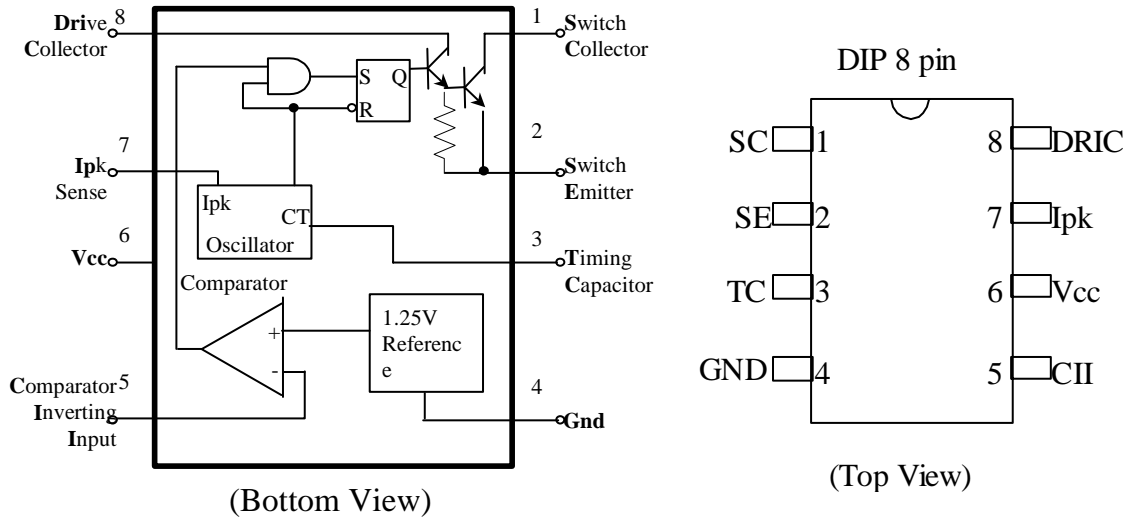

Typical Application

Step--Up Converter

PARAMETER	CONDITION	TYPE	UNIT
Line Regulation	Vin=8.0V to 16V, I _o =175mA	30±0.05%	mV
Load Regulation	Vin=12V, I _o =75mA to 175mA	10±0.017%	mV
Output Ripple	Vin=12V, I _o =175mA	400	mVp-p
Efficiency	Vin=12V, I _o =175mA	87.7%	-
Output Ripple with Optional Filter	Vin=12V, I _o =175mA	40	mVp-p

Step--Up Converter Schematic

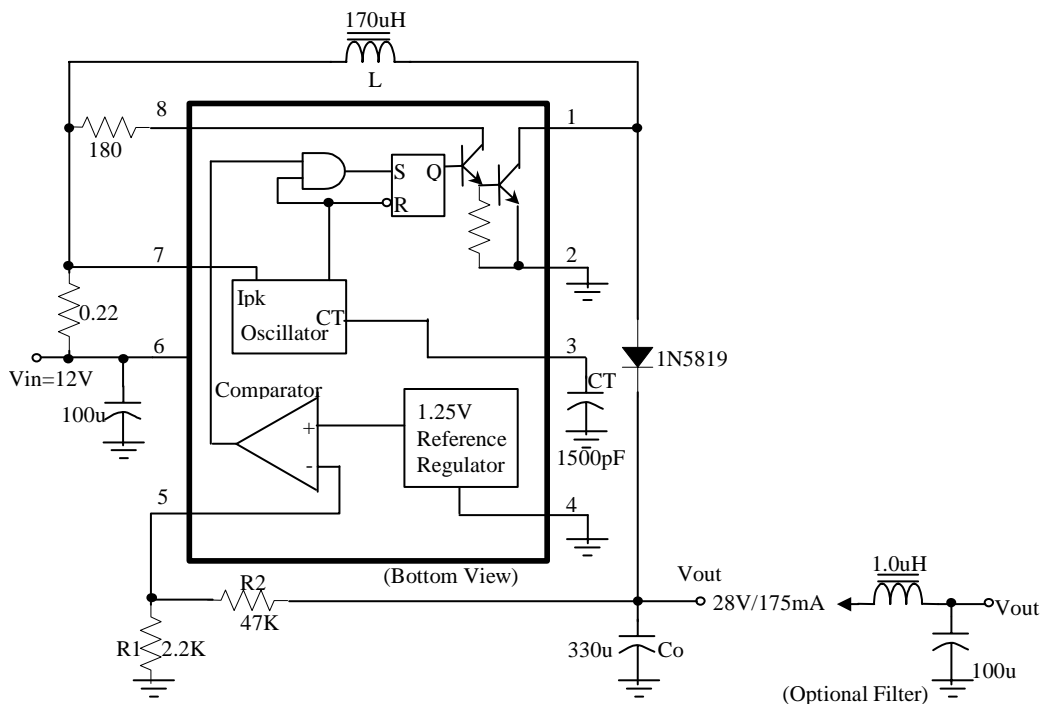

Typical Application

Step--Down Converter

PARAMETER	CONDITION	TYPE	UNIT
Line Regulation	V _{in} =15V to 25V, I _o =500mA	12±0.12%	mV
Load Regulation	V _{in} =25V, I _o =50mA to 500mA	3.0±0.03%	mV
Output Ripple	V _{in} =25V, I _o =500mA	120	mVp-p
Short Circuit Current	V _{in} =25V, R _L =0.1ohm	1.1	A
Efficiency	V _{in} =25V, I _o =500mA	83.7%	-
Output Ripple with Optional Filter	V _{in} =25V, I _o =500mA	40	mVp-p

Step--Down Converter Schematic

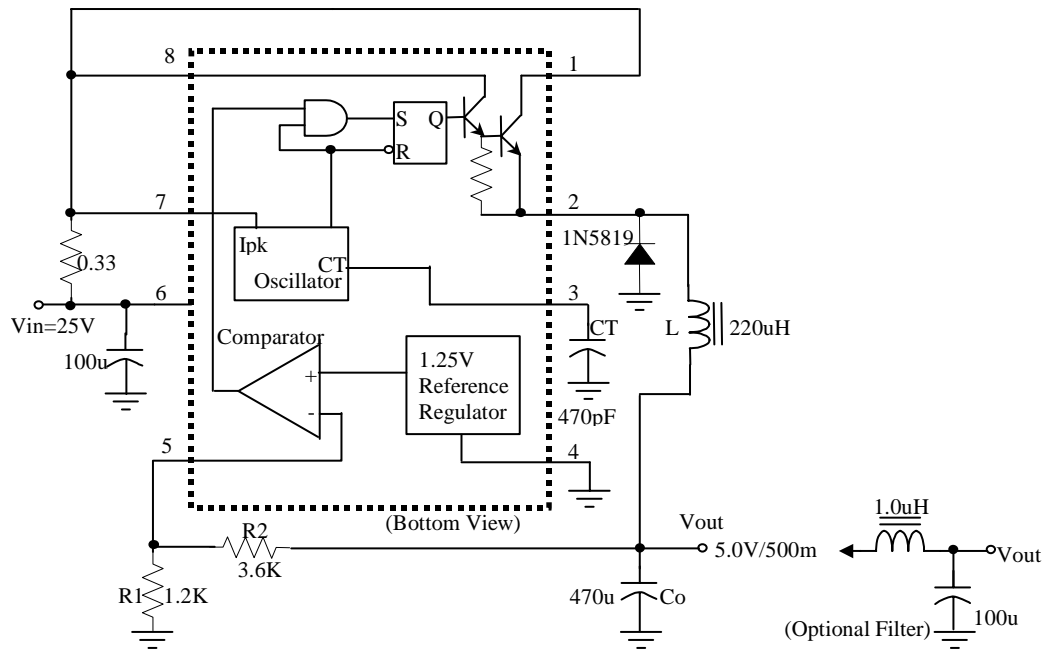

Typical Application

Voltage Inverting Converter

PARAMETER	CONDITION	TYPE	UNIT
Line Regulation	Vin=4.5V to 6.0V, I _o =100mA	3.0±0.012%	mV
Load Regulation	Vin=5.0V, I _o =10mA to 100mA	0.022±0.09%	mV
Output Ripple	Vin=5.0V, I _o =100mA	500	mVp-p
Short Circuit Current	Vin=5.0V, R _L =0.1ohm	910	mA
Efficiency	Vin=5.0V, I _o =100mA	62.2%	-
Output Ripple with Optional Filter	Vin=5.0V, I _o =100mA	70	mVp-p

Voltage Inverting Converter Schematic

