



## SOT-23 Plastic-Encapsulate Transistors

### MMBTH10LT1 TRANSISTOR (NPN)

#### FEATURES

Power dissipation

$$P_{CM}: 0.225 \text{ W (Tamb=25}^{\circ}\text{C)}$$

Collector current

$$I_{CM}: 0.05 \text{ A}$$

Collector-base voltage

$$V_{(BR)CBO}: 30 \text{ V}$$

Operating and storage junction temperature range

$$T_J, T_{stg}: -55^{\circ}\text{C to } +150^{\circ}\text{C}$$

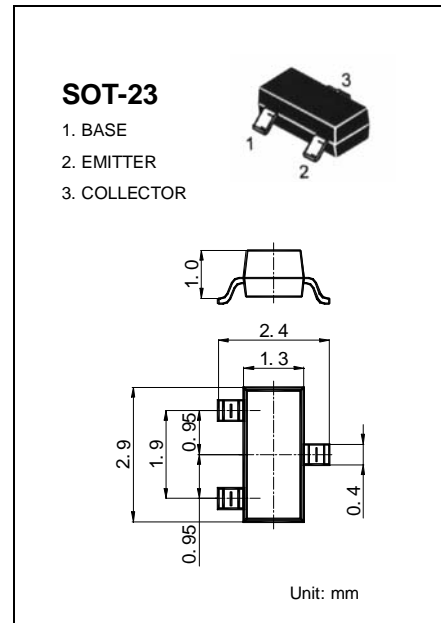

#### ELECTRICAL CHARACTERISTICS (Tamb=25°C unless otherwise specified)

Parameter	Symbol	Test conditions	MIN	MAX	UNIT
Collector-base breakdown voltage	$V_{(BR)CBO}$	$I_C = 100\mu\text{A}, I_E = 0$	30		V
Collector-emitter breakdown voltage	$V_{(BR)CEO}$	$I_C = 1 \text{ mA}, I_B = 0$	25		V
Emitter-base breakdown voltage	$V_{(BR)EBO}$	$I_E = 10\mu\text{A}, I_C = 0$	3		V
Collector cut-off current	$I_{CBO}$	$V_{CB} = 25\text{V}, I_E = 0$		0.1	$\mu\text{A}$
Emitter cut-off current	$I_{EBO}$	$V_{EB} = 2\text{V}, I_C = 0$		0.1	$\mu\text{A}$
DC current gain	$h_{FE(1)}$	$V_{CE} = 10\text{V}, I_C = 4\text{mA}$	60		
Collector-emitter saturation voltage	$V_{CE(sat)}$	$I_C = 4 \text{ mA}, I_B = 0.4\text{mA}$		0.5	V
Base-emitter voltage	$V_{BE(on)}$	$V_{CE} = 10\text{V}, I_C = 4\text{mA}$		0.95	V
Transition frequency	$f_T$	$V_{CE} = 10\text{V}, I_C = 4\text{mA}$ $f = 100\text{MHz}$	650		MHz

#### DEVICE MARKING

MMBTH10LT1=3EM