



PROGRAMMABLE PRECISION REFERENCES

The TL431 is three-terminal adjustable shunt regulator with specified thermal stability.

The output voltage may be set to any value between V_{REF} (Approx. 2.5V) and 36V with two external resistors.

This device has a typical output impedance of 0.2Ω .

Active output circuitry provides a very sharp turn-on characteristic, making this device excellent replacement for zener diodes in many applications.

FEATURES

- Equivalent Full Range Temperature Coefficient 50PPM/°C
- Temperature Compensated For Operation Over Full Rate Operating Temperature Range
- Adjustable Output Voltage
- Fast Turn-on Response
- Sink Current Capability 1mA to 100mA
- Low (0.2Ω Typ.) Dynamic Output Impedance
- Low Output Noise

FUNCTION BLOCK DIAGRAM

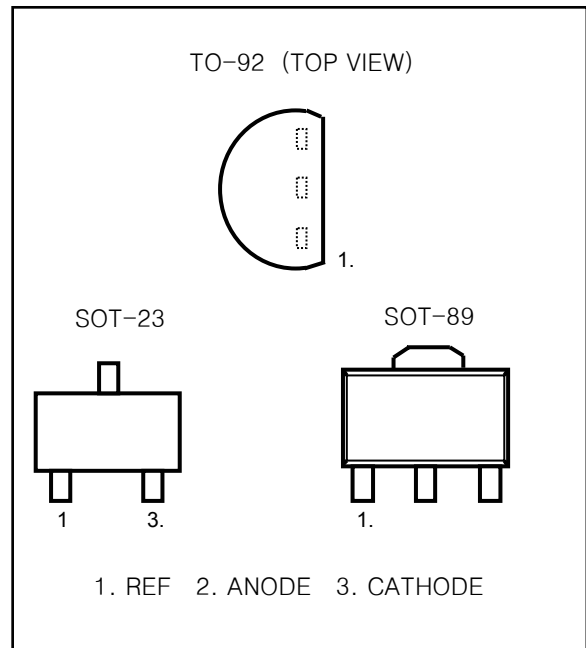
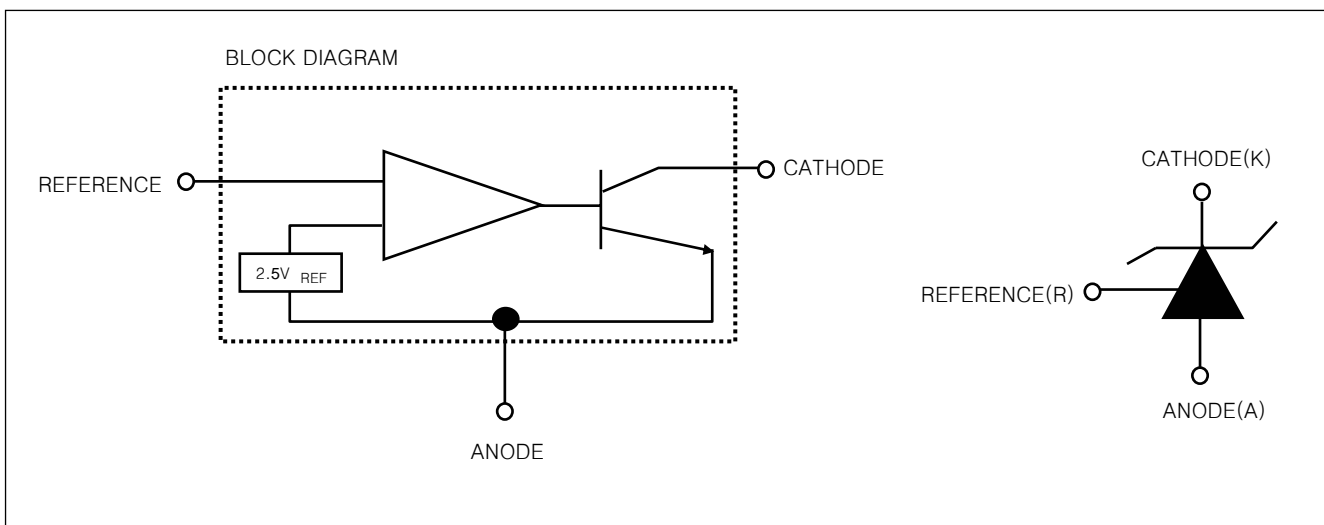



SHENZHEN TUOFENG

TF TL431/A

ABSOLUTE MAXIMUM RATINGS

(Full Operating Ambient Temperature Range Applies Unless Otherwise Noted)

CHARACTERISTIC	SYMBOL	RATING	UNIT
Cathode Voltage	V_{KA}	37	V
Continuous Cathode Current Range	I_{KA}	-100~+150	mA
Reference Input Current Range	I_{REF}	0.05~10	mA
Junction Temperature	T_J	150	°C
Operating Temperature	T_{OPR}	-20 ~ 85	°C
Storage Temperature	T_{STG}	-65 ~ 150	°C
Total Power Dissipation	P_D	700	mW

TL431A-0.3% ELECTRICAL CHARACTERISTIC ($T_A=25^\circ\text{C}$, unless otherwise specified)

CHARACTERISTIC	SYMBOL	CIR-CUIT	TEST CONDITION	MIN.	TYP.	MAX.	UNIT
Reference Input Voltage	V_{REF}	1	$V_{KA}=V_{REF}, I_K=10\text{mA}$	2.487V	2.495V	2.502V	
Deviation of Reference Input Voltage Over Full Temperature Range	$\Delta V_{REF}/\Delta T$	1	$V_{KA}=V_{REF}, I_K=10\text{mA}$ $T_A=\text{Full Range}$		3	17	mV
Ratio of Change in Reference Input Voltage to the Change in Cathode Voltage	$\Delta V_{REF}/\Delta V_{KA}$	2	$I_K=10\text{mA}$	$\Delta V_{KA}=10\text{V}-V_{REF}$	-1.4	-2.7	mV/V
				$\Delta V_{KA}=36\text{V}-10\text{V}$	-1	-2	
Reference Input Current	I_{REF}	2	$I_{KA}=10\text{mA}, R1=10\text{k}\Omega, R2=\infty$		1.8	4	μA
Deviation of Reference Input Current Over Full Temperature Range	$\Delta I_{REF}/\Delta T$	2	$I_K=10\text{mA}, R1=10\text{k}\Omega, R2=\infty$ $T_A=\text{Full Range}$		0.4	1.2	μA
Minimum Cathode Current for Regulation	$I_{KA\text{MIN}}$	1	$\Delta V_{KA}=V_{REF}$		0.5	1	mA
Off-State Cathode Current	$I_{KA\text{OFF}}$	3	$V_{KA}=36\text{V}, V_{REF}=0$		0.2	1	μA
Dynamic Impedance	Z_{KA}	1	$V_{KA}=V_{REF}, I_K=1\text{mA}\sim 100\text{mA},$ $f\leq 1\text{kHz}$		0.2	0.5	Ω

TF TL431/A

TL431A-0.5%ELECTRICAL CHARACTERISTIC

($T_A=25^{\circ}\text{C}$, unless otherwise specified)

CHARACTERISTIC	SYMBOL	CIR-CUIT	TEST CONDITION	MIN.	TYP.	MAX.	UNIT
Reference Input Voltage	V_{REF}	1	$V_{KA}=V_{REF}, I_K=10\text{mA}$	2.482V	2.495V	2.507V	
Deviation of Reference Input Voltage Over Full Temperature Range	$\Delta V_{REF}/\Delta T$	1	$V_{KA}=V_{REF}, I_K=10\text{mA}$ $T_A=\text{Full Range}$		3	17	mV
Ratio of Change in Reference Input Voltage to the Change in Cathod Voltage	$\Delta V_{REF}/\Delta V_{KA}$	2	$I_K=10\text{mA}$	$\Delta V_{KA}=10\text{V}-V_{REF}$	-1.4	-2.7	mV/V
				$\Delta V_{KA}=36\text{V}-10\text{V}$	-1	-2	
Reference Input Current	I_{REF}	2	$I_{KA}=10\text{mA}, R1=10\text{k}\Omega, R2=\infty$		1.8	4	μA
Deviation of Reference Input Current Over Full Temperature Range	$\Delta I_{REF}/\Delta T$	2	$I_K=10\text{mA}, R1=10\text{k}\Omega, R2=\infty$ $T_A=\text{Full Range}$		0.4	1.2	μA
Minimum Cathode Current for Regulation	$I_{KA\text{MIN}}$	1	$\Delta V_{KA}=V_{REF}$		0.5	1	mA
Off-State Cathode Current	$I_{KA\text{OFF}}$	3	$V_{KA}=36\text{V}, V_{REF}=0$		0.2	1	μA
Dynamic Impedance	Z_{KA}	1	$V_{KA}=V_{REF}, I_K=1\text{mA}\sim 100\text{mA},$ $f\leq 1\text{kHz}$		0.2	0.5	Ω

TL431A-1%ELECTRICAL CHARACTERISTIC

($T_A=25^{\circ}\text{C}$, unless otherwise specified)

CHARACTERISTIC	SYMBOL	CIR-CUIT	TEST CONDITION	MIN.	TYP.	MAX.	UNIT
Reference Input Voltage	V_{REF}	1	$V_{KA}=V_{REF}, I_K=10\text{mA}$	2.47V	2.495V	2.52V	
Deviation of Reference Input Voltage Over Full Temperature Range	$\Delta V_{REF}/\Delta T$	1	$V_{KA}=V_{REF}, I_K=10\text{mA}$ $T_A=\text{Full Range}$		3	17	mV
Ratio of Change in Reference Input Voltage to the Change in Cathod Voltage	$\Delta V_{REF}/\Delta V_{KA}$	2	$I_K=10\text{mA}$	$\Delta V_{KA}=10\text{V}-V_{REF}$	-1.4	-2.7	mV/V
				$\Delta V_{KA}=36\text{V}-10\text{V}$	-1	-2	
Reference Input Current	I_{REF}	2	$I_{KA}=10\text{mA}, R1=10\text{k}\Omega, R2=\infty$		1.8	4	μA
Deviation of Reference Input Current Over Full Temperature Range	$\Delta I_{REF}/\Delta T$	2	$I_K=10\text{mA}, R1=10\text{k}\Omega, R2=\infty$ $T_A=\text{Full Range}$		0.4	1.2	μA
Minimum Cathode Current for Regulation	$I_{KA\text{MIN}}$	1	$\Delta V_{KA}=V_{REF}$		0.5	1	mA
Off-State Cathode Current	$I_{KA\text{OFF}}$	3	$V_{KA}=36\text{V}, V_{REF}=0$		0.2	1	μA
Dynamic Impedance	Z_{KA}	1	$V_{KA}=V_{REF}, I_K=1\text{mA}\sim 100\text{mA},$ $f\leq 1\text{kHz}$		0.2	0.5	Ω

TF TL431/A

Fig. 1 Test Circuit for $V_{KA} = V_{REF}$

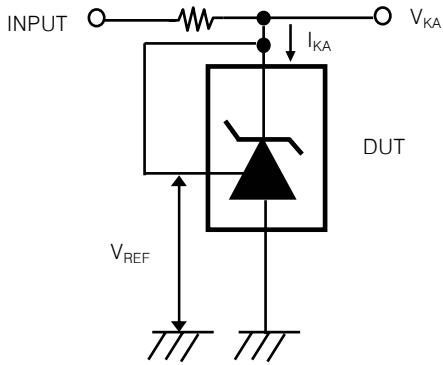

Fig. 2 Test Circuit for $V_{KA} \geq V_{REF}$

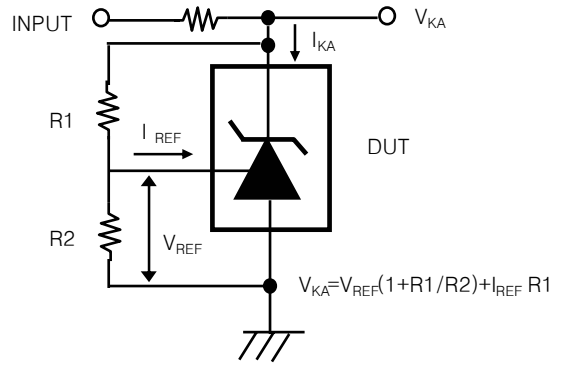
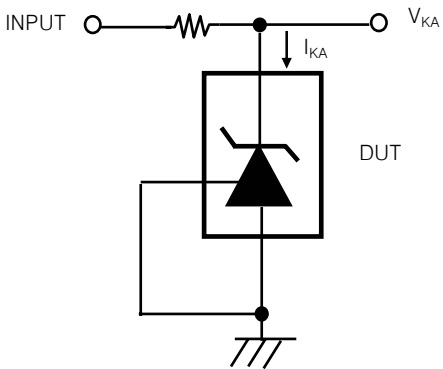

Fig. 3 Test Circuit for I_{KA} (off)



TF TL431/A

TYPICAL PERFORMANCE CHARACTERISTICS

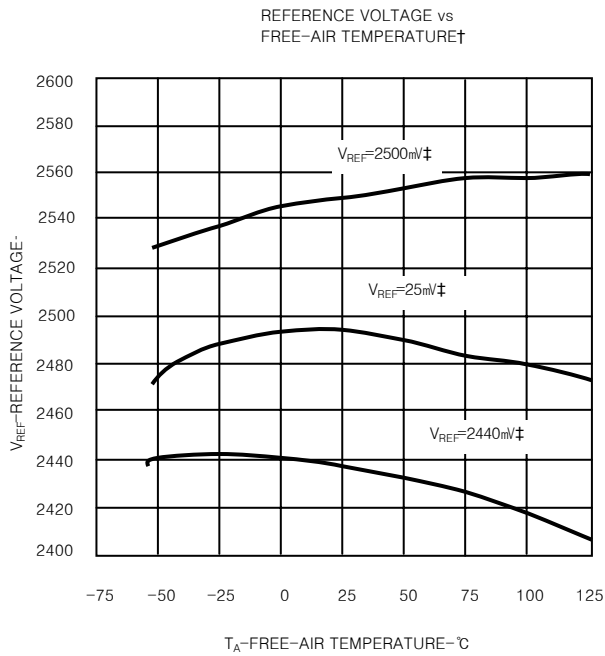

Figure 4.

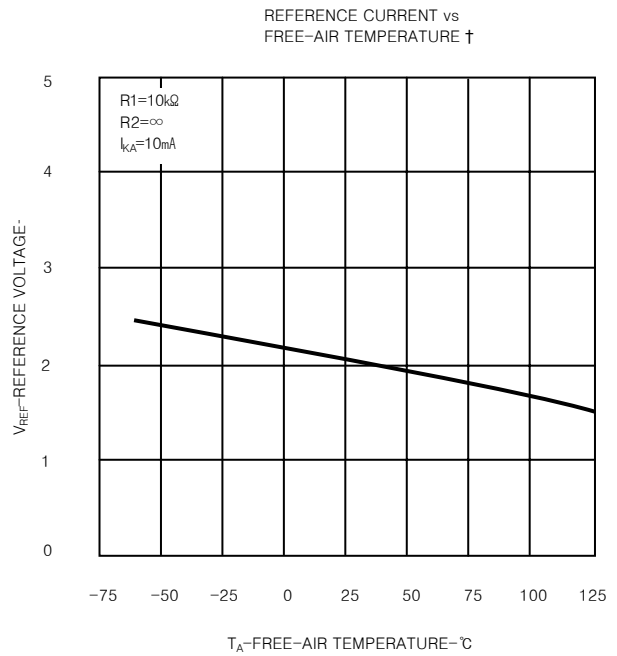

Figure 5.

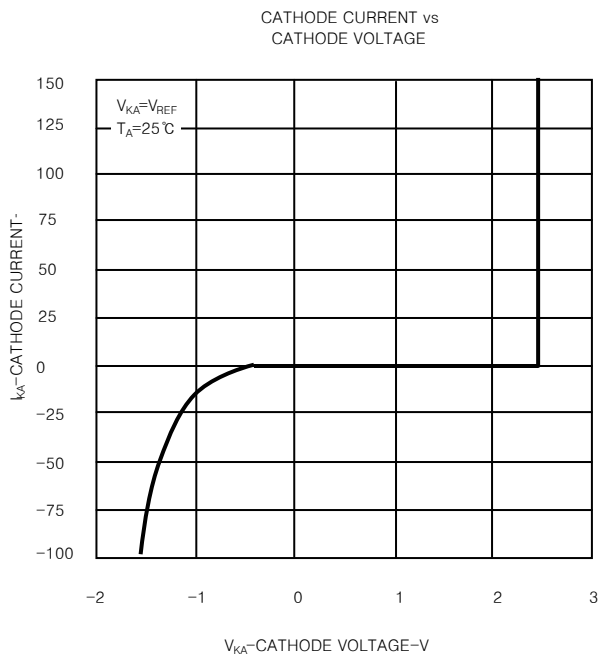

Figure 6.

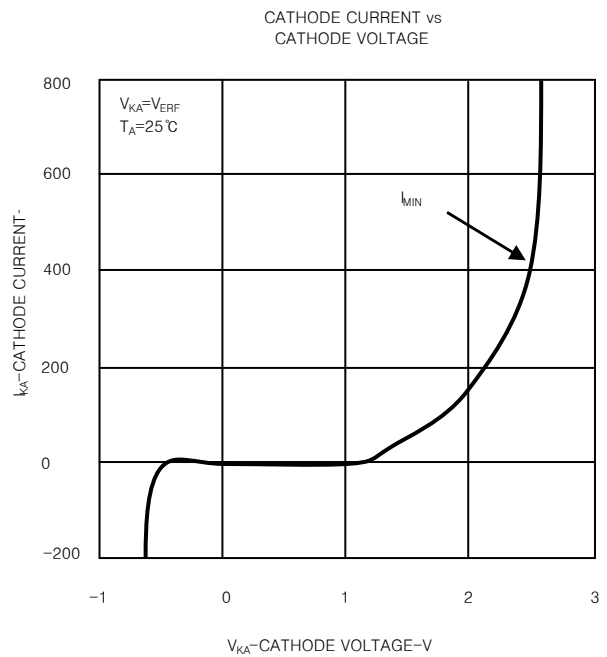
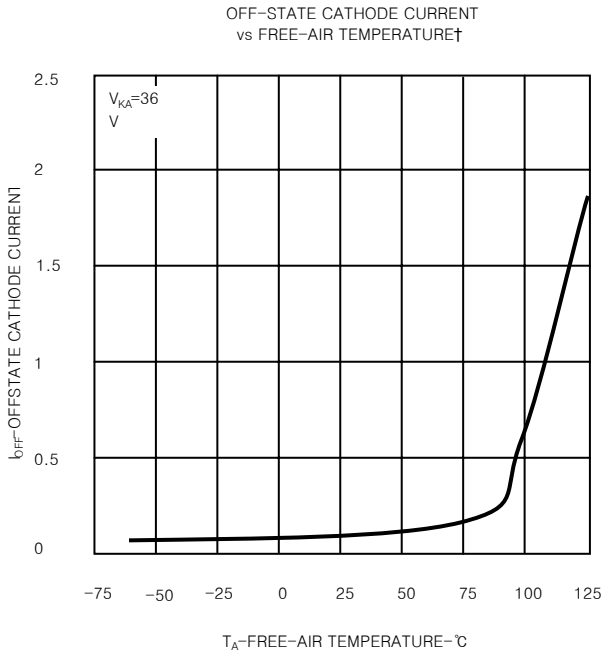

Figure 7.

TF TL431/A

TYPICAL PERFORMANCE CHARACTERISTICS



† Data is applicable only within the recommended operating free-air temperature ranges of the various devices.

Figure 8.

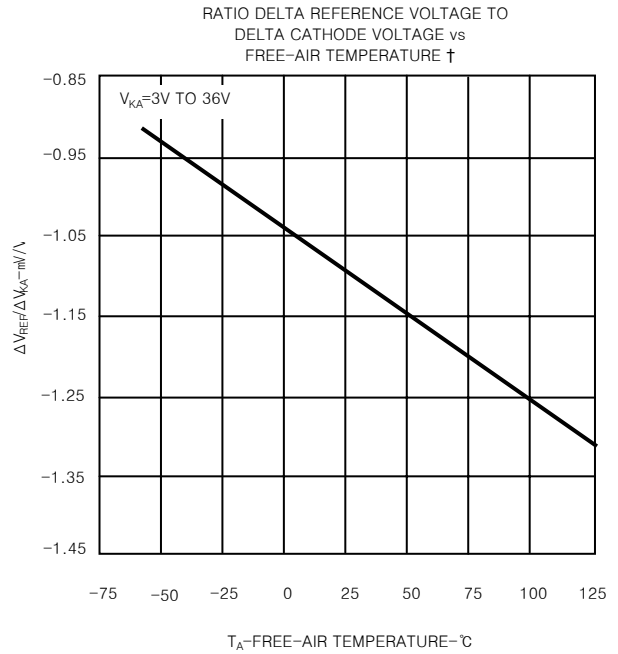

† Data is applicable only within the recommended operating free-air temperature ranges of the various devices.

Figure 9.

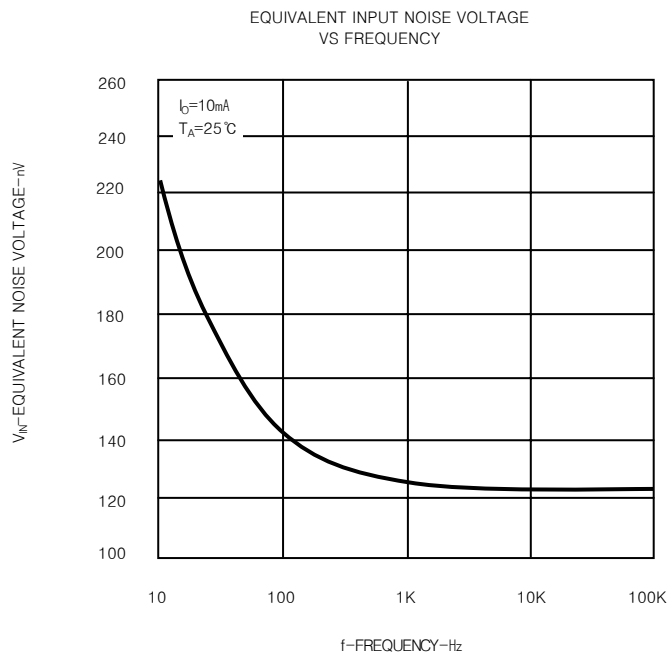

Figure 10.

TF TL431/A

TYPICAL PERFORMANCE CHARACTERISTICS

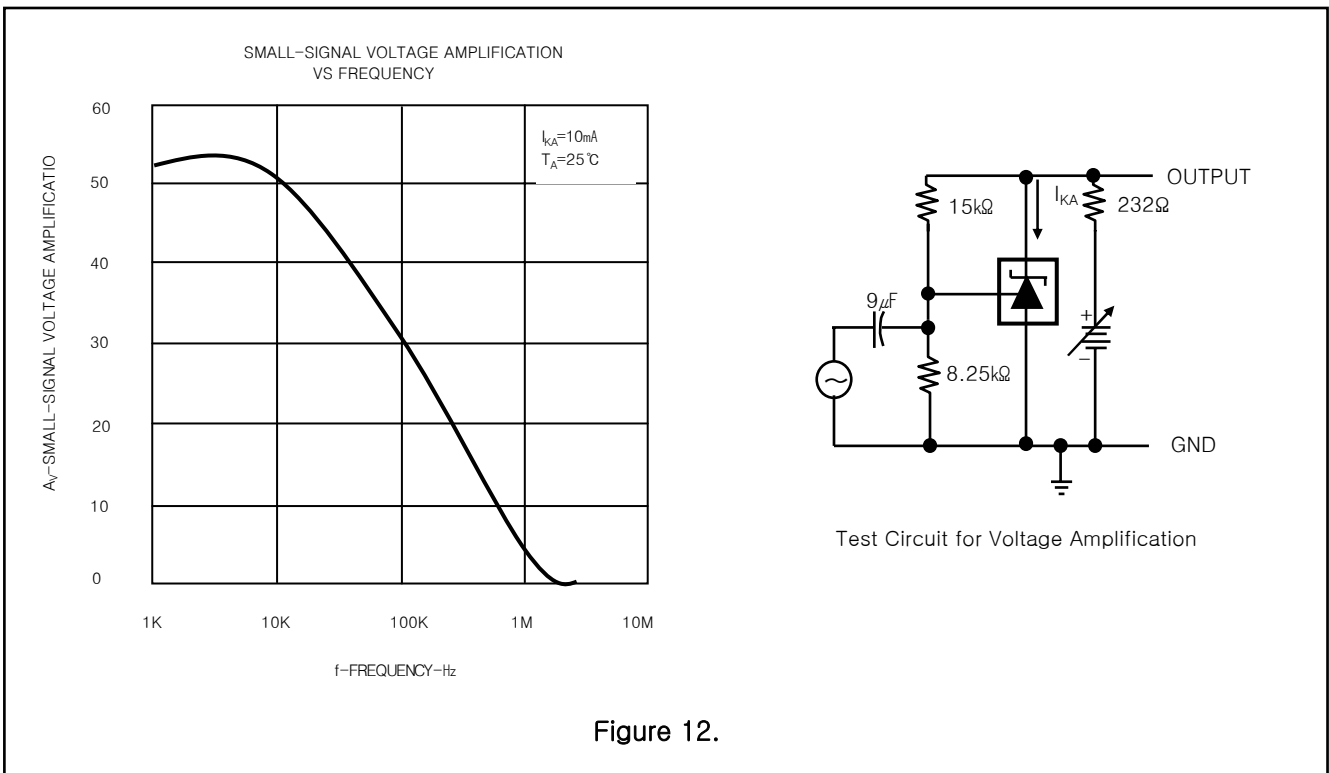
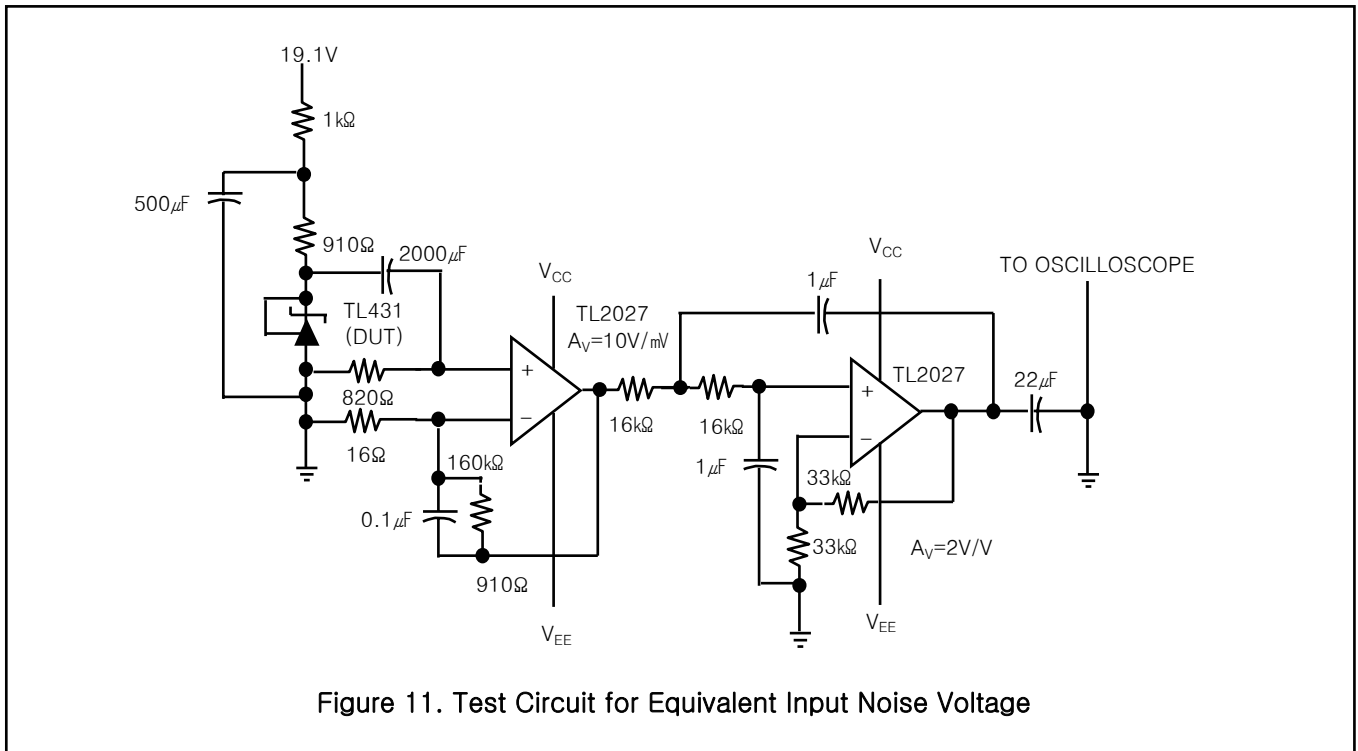

Figure 12.

TF TL431/A

TYPICAL PERFORMANCE CHARACTERISTICS

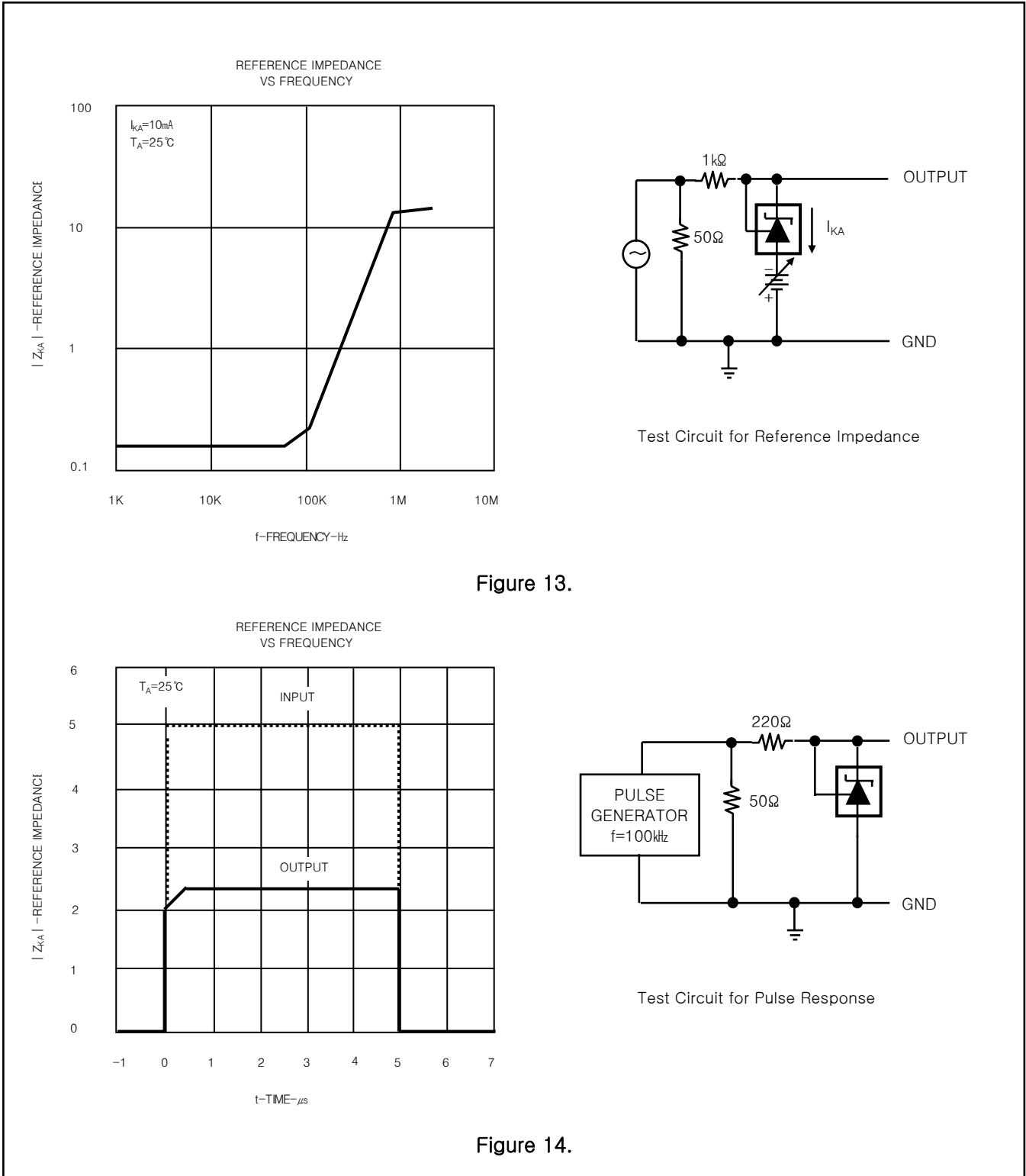

Figure 13.

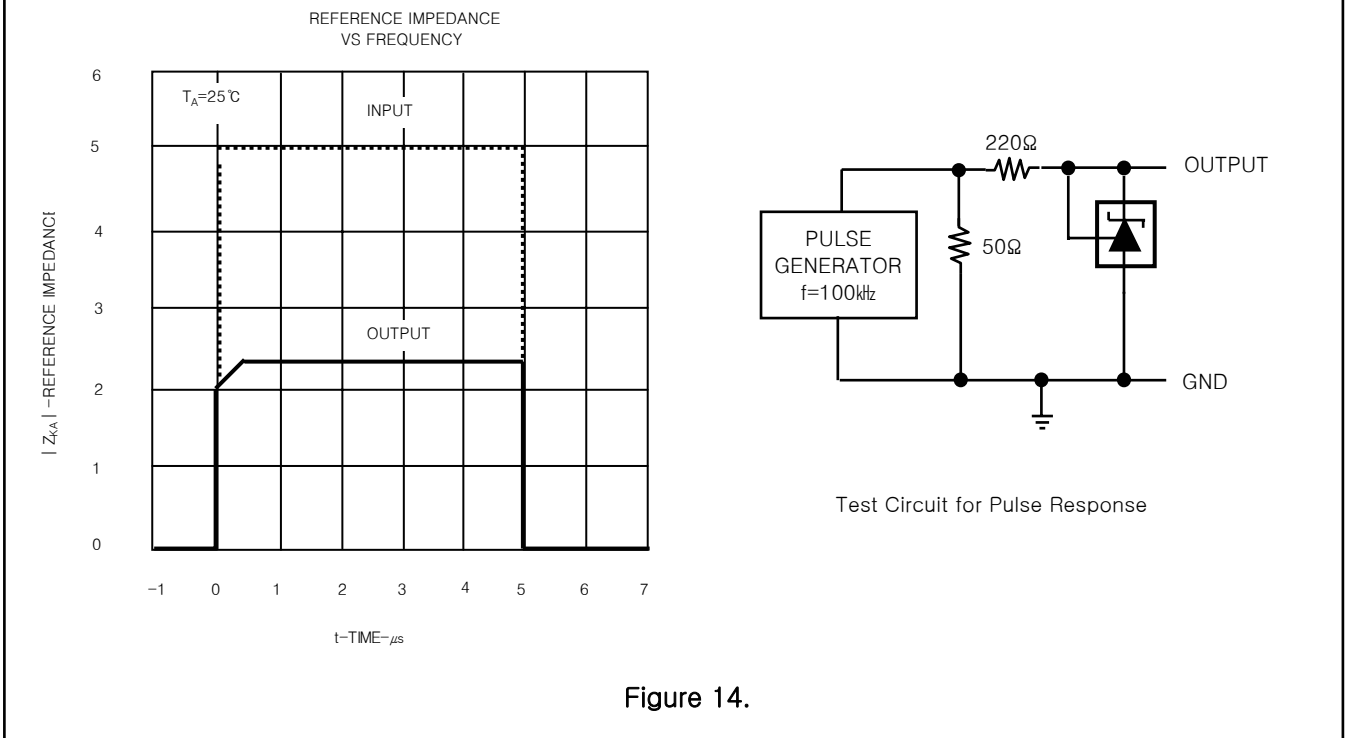
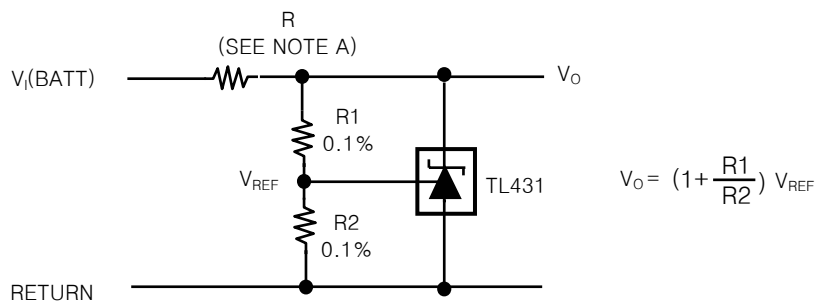

Figure 14.

TF TL431/A

APPLICATION INFORMATION



NOTE A : R Should provide cathode current $\geq 1\text{mA}$ to the TL431 at minimum $V_I(\text{BATT})$

Figure 15. Shunt Regulator

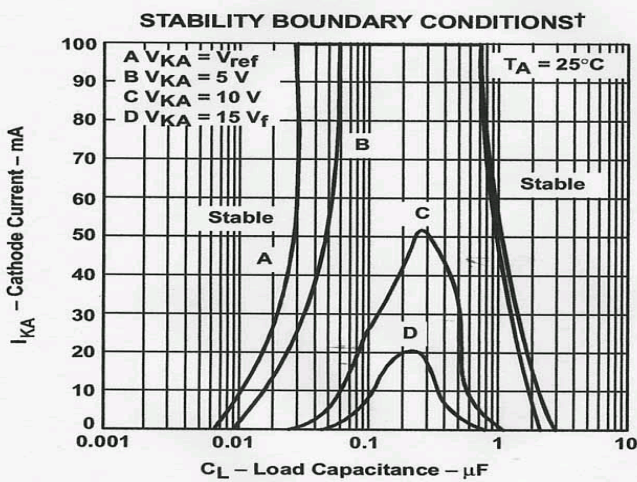

† The areas under the curves represent conditions that may cause the device to oscillate. For curves B, C, and D, R2 and V+ were adjusted to establish the initial V_{KA} and I_{KA} conditions with $C_L = 0$. V_{BATT} and C_L then were adjusted to determine the ranges of stability.

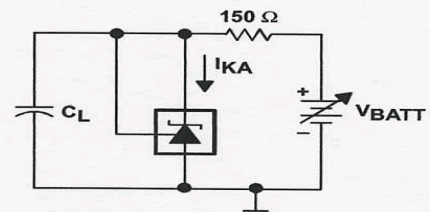

TEST CIRCUIT FOR CURVE A

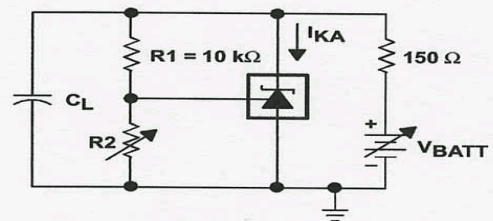

TEST CIRCUIT FOR CURVES B, C, AND D

Figure 16

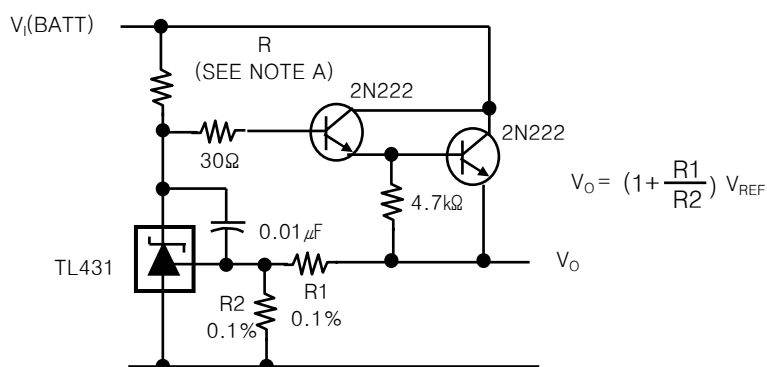

NOTE A : R Should provide cathode current $\geq 1\text{mA}$ to the TL431 at minimum $V_I(\text{BATT})$

Figure 17. Precision High-Current Series Regulator

TF TL431/A

APPLICATION INFORMATION

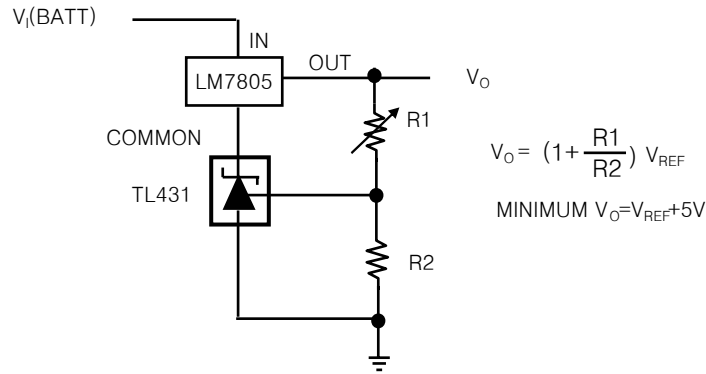

Figure 18. Output Control of a 3-Terminal Fixed Regulator

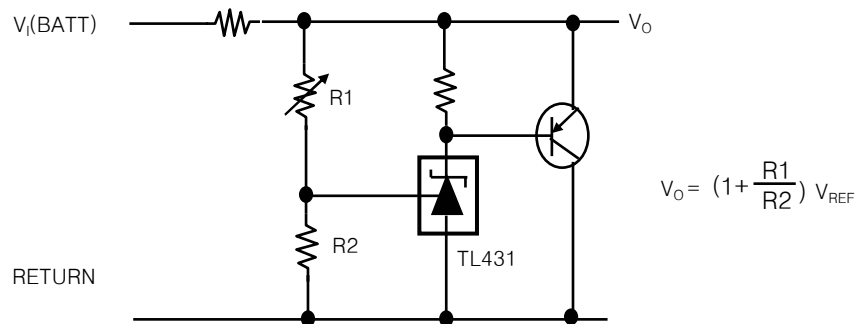
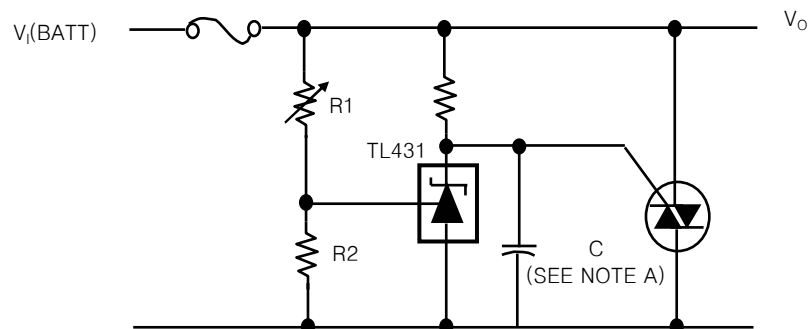

Figure 19. High-Current Shunt Regulator



NOTE A : Refer to the stability boundary conditions in Figure 16 to determine allowable values for C.

Figure 20. Crowbar Circuit

TF TL431/A

APPLICATION INFORMATION

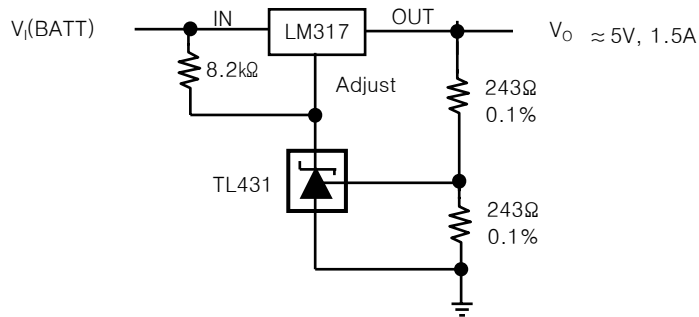
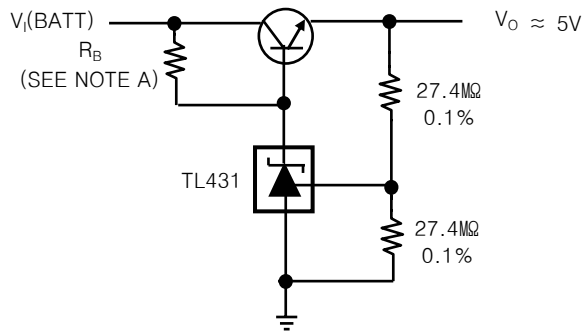

Figure 21. Precision 5-V 1.5A Regulator



NOTE A : R_B Should provide cathode current $\geq 1\text{mA}$ to the TL431.

Figure 22. Efficient 5-V Precision Regulator

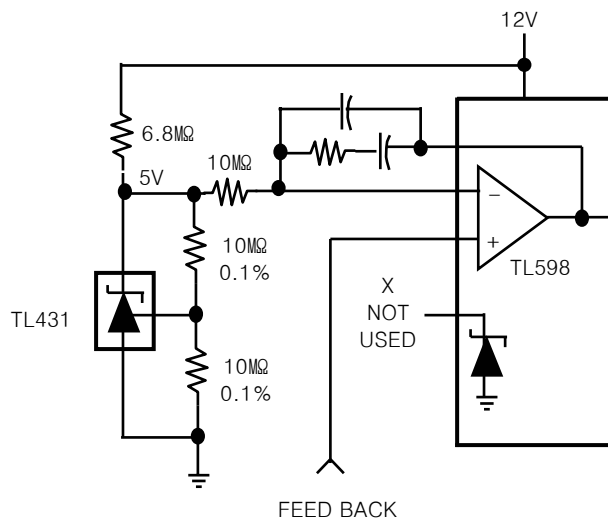
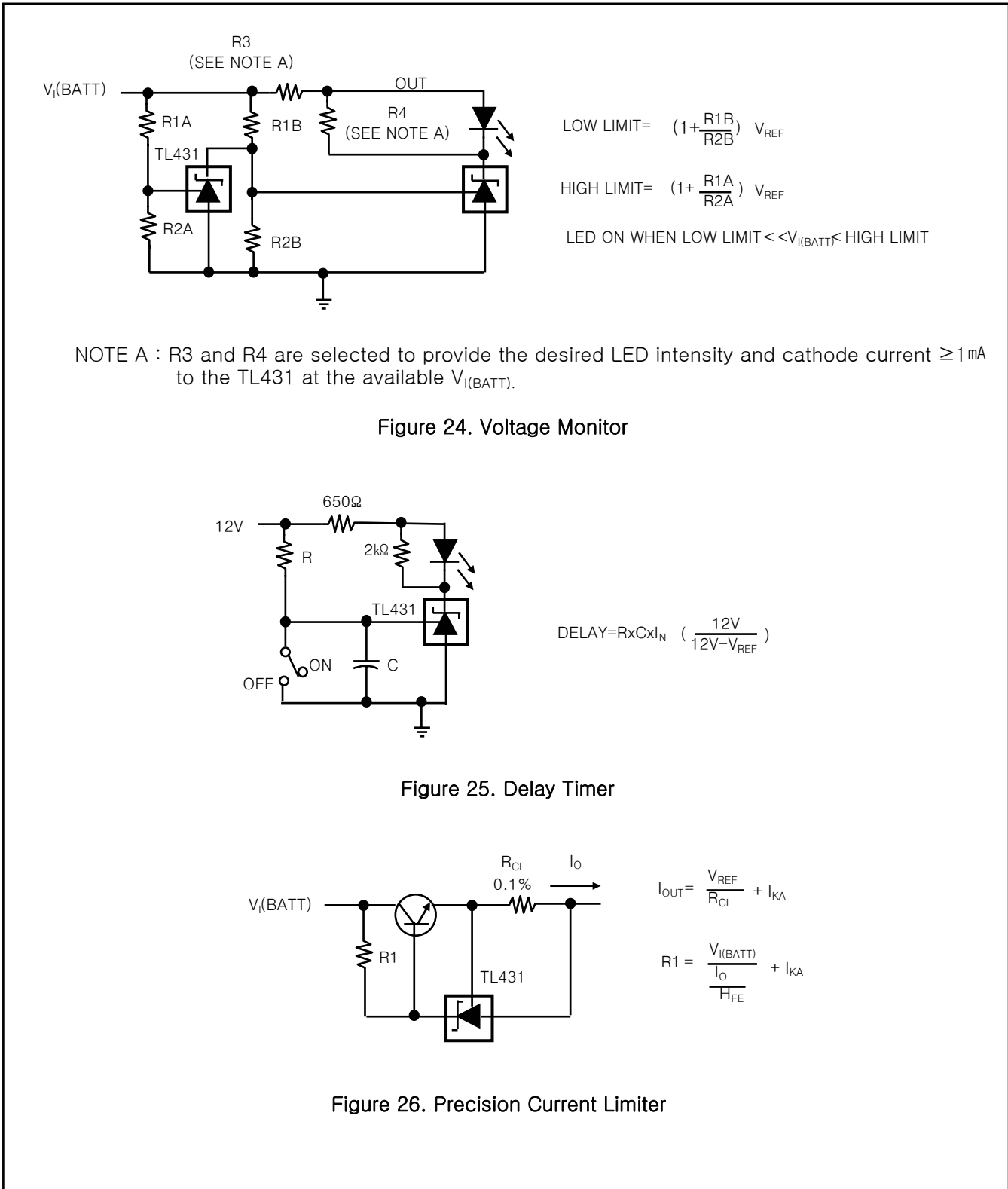

Figure 23. PWM Converter With Reference

APPLICATION INFORMATION



APPLICATION INFORMATION

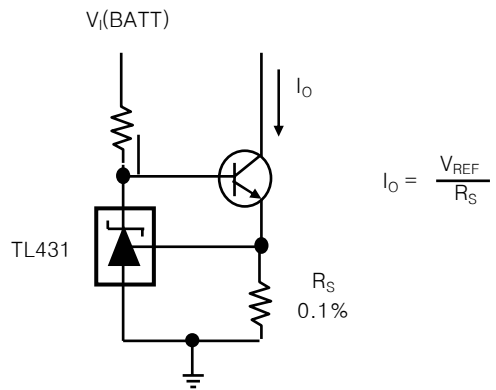

Figure 27. Precision Constant-Current Sink