

TF3420 N-Channel 20-V(D-S) MOSFET

$V_{(BR)DSS}$	$R_{DS(on)TYP}$	I_D
20V	0.015Ω@4.5V	6A
	0.018Ω@2.5V	

General FEATURE

- TrenchFET Power MOSFET
- Lead free product is acquired
- Surface mount package

APPLICATION

- Load Switch for Portable Devices
- DC/DC Converter

SOT-23

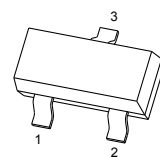

1
2
3

1.GATE
2.SOURCE
3.DRAIN

MARKING

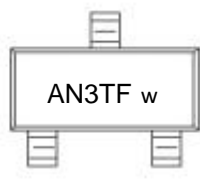

AN3TF w

*w: week code

Equivalent Circuit

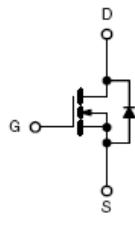

Maximum ratings ($T_a=25^{\circ}C$ unless otherwise noted)

Parameter	Symbol	Value	Unit
Drain-Source Voltage	V_{DS}	20	V
Gate-Source Voltage	V_{GS}	±12	
Continuous Drain Current	I_D	6.0	A
Pulsed Drain Current*1	I_{DM}	20	
Continuous Source-Drain Diode Current	I_S	1.25	
Maximum Power Dissipation	P_D	1.25	W
Thermal Resistance from Junction to Ambient($t \leq 10s$)	$R_{\theta JA}$	100	$^{\circ}C/W$
Junction Temperature	T_J	150	$^{\circ}C$
Storage Temperature	T_{stg}	-55 ~+150	

Note :

*1. Pulse Width $\leq 300\mu s$, Duty cycle $\leq 2\%$



SOT-23 Plastic-Encapsulate MOSFETS

TF3420

MOSFET ELECTRICAL CHARACTERISTICS

T_a =25 °C unless otherwise specified

Parameter	Symbol	Test Condition	Min	Typ	Max	Units
Static						
Drain-source breakdown voltage	V _{(BR)DSS}	V _{GS} = 0V, I _D = 250μA	20			V
Gate-source threshold voltage	V _{GS(th)}	V _{DS} =V _{GS} , I _D = 250μA	0.5	0.6	1.0	
Gate-source leakage	I _{GSS}	V _{DS} =0V, V _{GS} =±12V			±100	nA
Zero gate voltage drain current	I _{DSS}	V _{DS} =16V, V _{GS} =0V			100	nA
Drain-source on-state resistance ^a	R _{DS(on)}	V _{GS} =4.5V, I _D =6A		0.015	0.018	Ω
		V _{GS} =2.5V, I _D =5A		0.018	0.025	
Forward transconductance ^a	g _{fs}	V _{DS} =5V, I _D =6A		25	-	S
Dynamic^b						
Input capacitance	C _{iss}	V _{DS} =15V, V _{GS} =0V, f =1MHz		742		pF
Output capacitance	C _{oss}			66		
Reverse transfer capacitance	C _{rss}			78		
Total gate charge	Q _g	V _{DS} =10V, V _{GS} =4.5V, I _D =6A		9.0		nC
Gate-source charge	Q _{gs}			1.5		
Gate-drain charge	Q _{gd}			2.6		
Turn-on delay time	t _{d(on)}	V _{DD} =10V, I _D =1A V _{GEN} =4.5V, R _g =6Ω		12.0		ns
Rise time	t _r			23.0		
Turn-off delay time	t _{d(off)}			14.0		
Fall time	t _f			9.0		
Drain-source body diode characteristics						
Continuous source-drain diode current	I _S	T _C =25°C			1.25	A
Body diode voltage	V _{SD}	I _S =1.0A		0.7	1.0	V

Notes :

a.Pulse Test : Pulse Width < 300μs, Duty Cycle ≤2%.

b.Guaranteed by design, not subject to production testing.

Typical Characteristics

Typical Output Characteristics

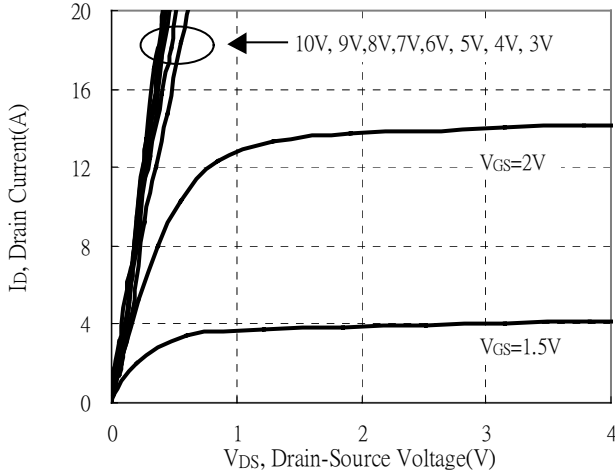

Brekdown Voltage vs Ambient Temperature

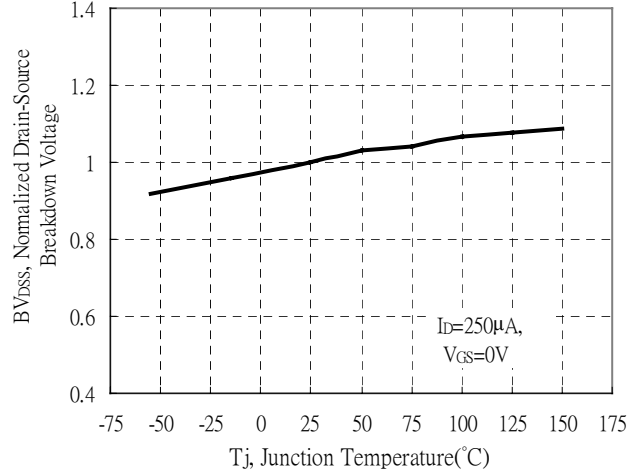

Static Drain-Source On-State resistance vs Drain Current

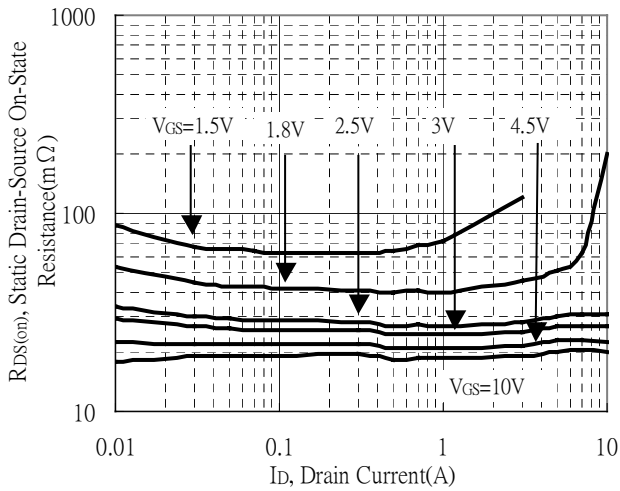

Reverse Drain Current vs Source-Drain Voltage

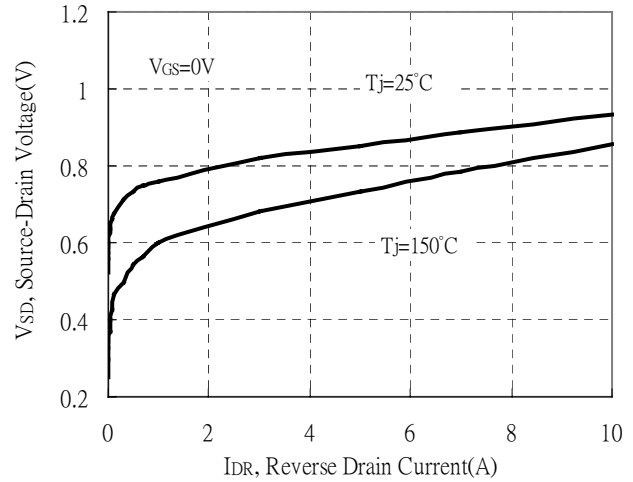

Static Drain-Source On-State Resistance vs Gate-Source Voltage

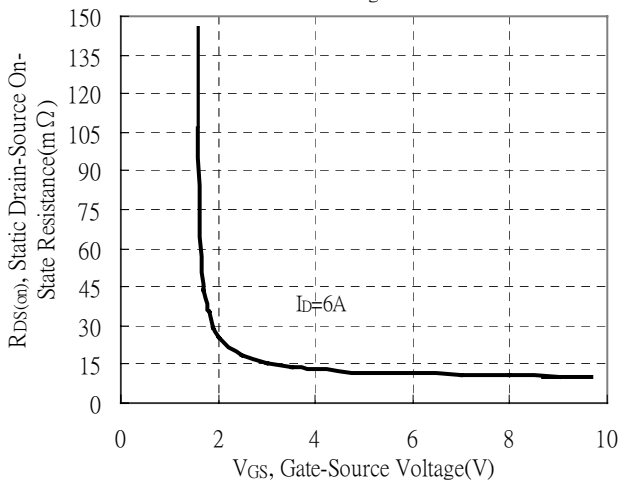

Drain-Source On-State Resistance vs Junction Temperature

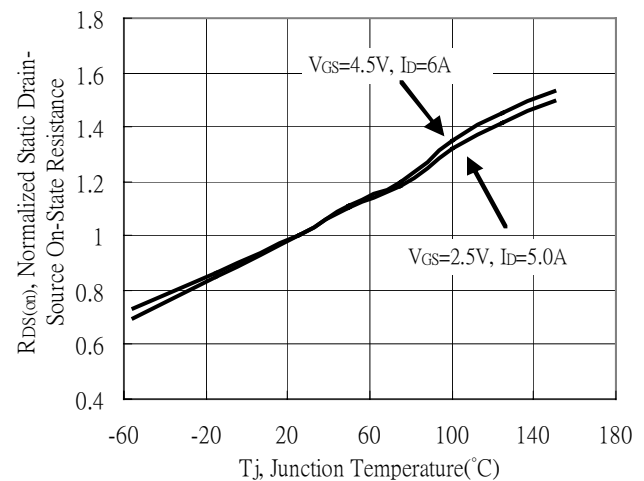

Typical Characteristics(Cont.)

Capacitance vs Drain-to-Source Voltage

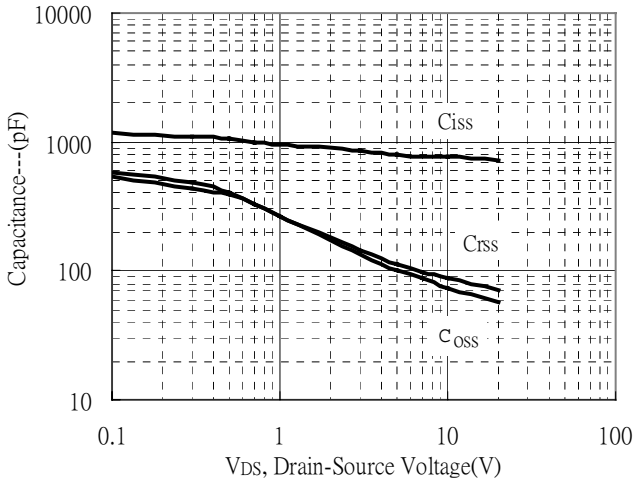

Threshold Voltage vs Junction Temperature

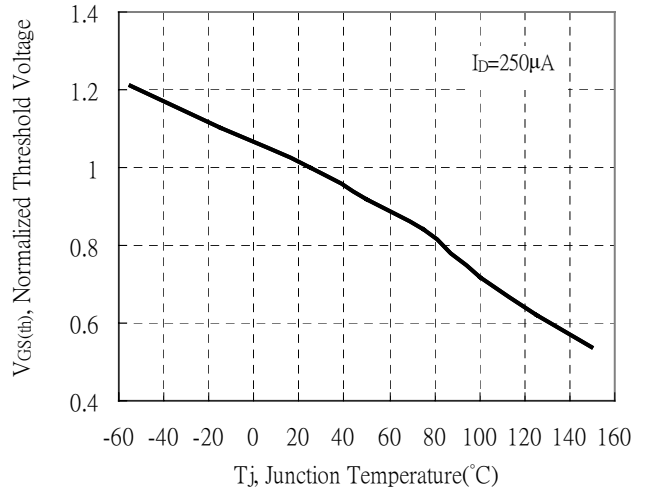

Forward Transfer Admittance vs Drain Current

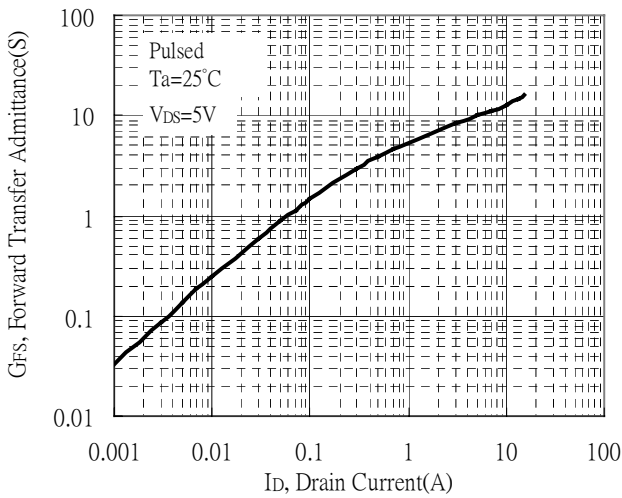

Gate Charge Characteristics

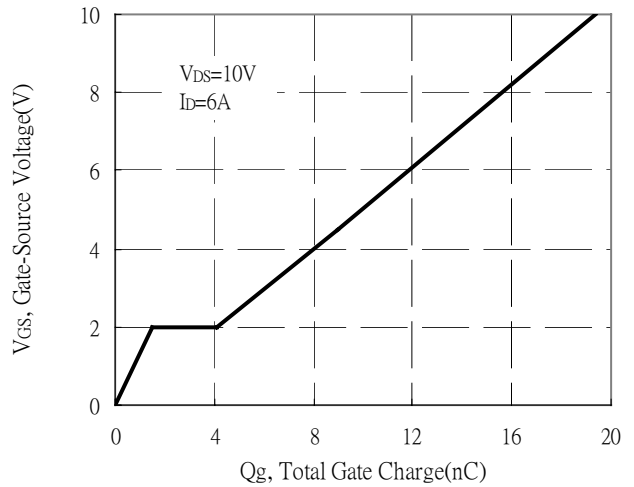

Maximum Safe Operating Area

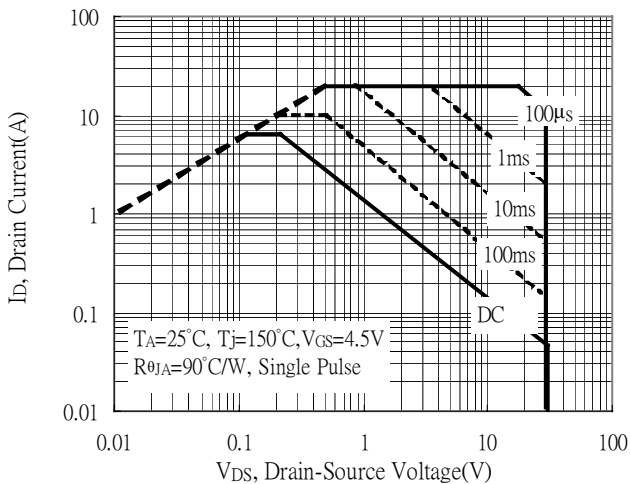

Maximum Drain Current vs Junction Temperature

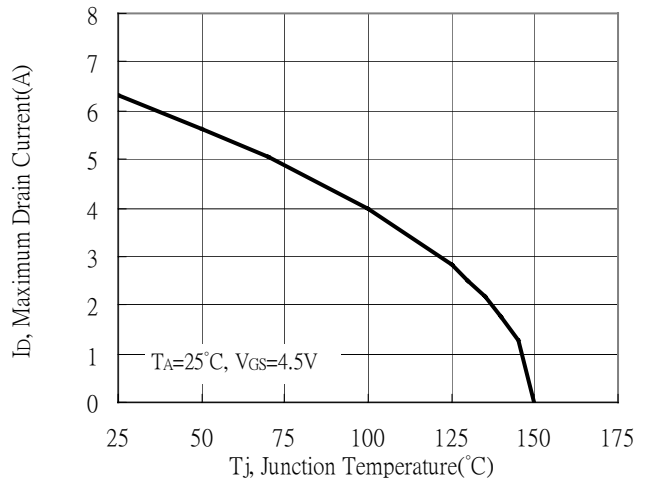

Typical Characteristics(Cont.)

Power Derating Curve

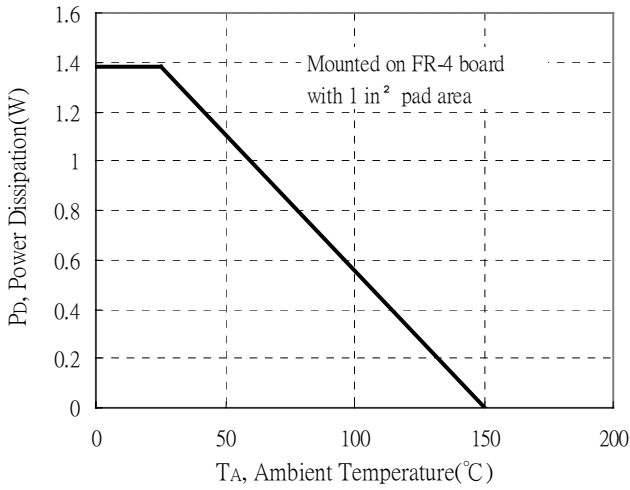

Single Pulse Power Rating, Junction to Ambient (Note on page 1)

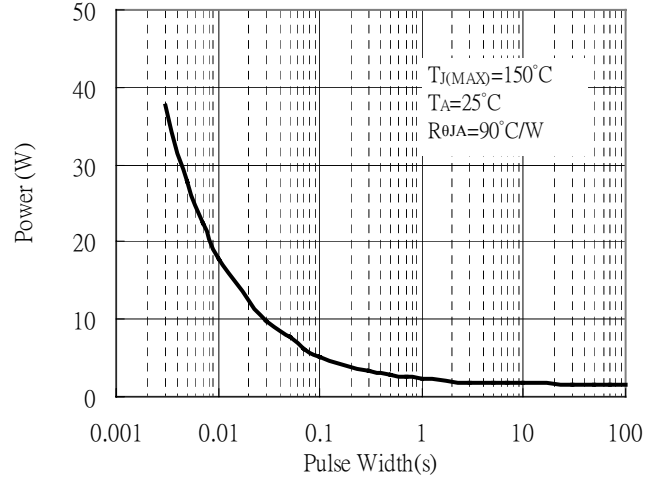

Transient Thermal Response Curves

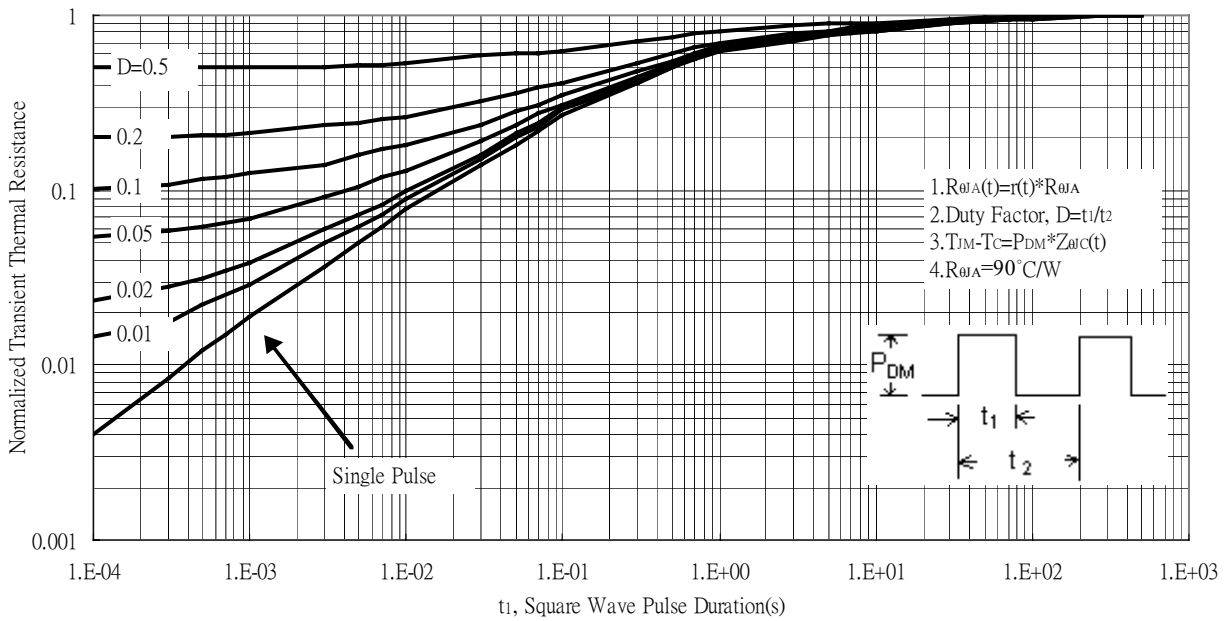

SOT-23 Plastic-Encapsulate MOSFETS

TF3420

SOT-23 Package Outline Dimensions

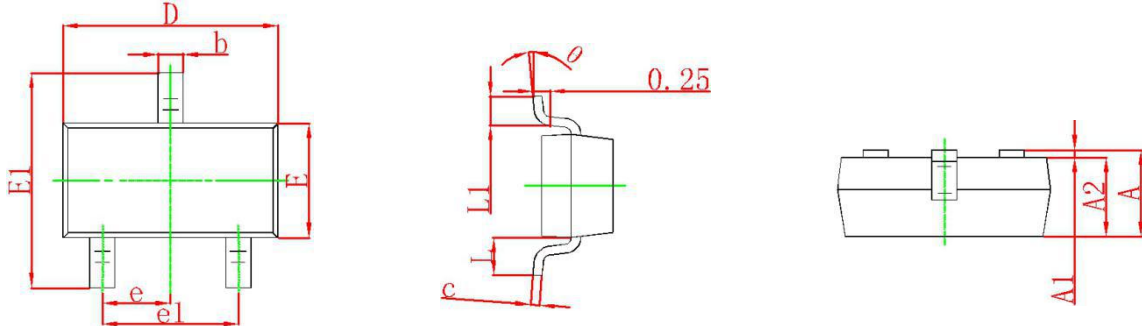

Symbol	Dimensions In Millimeters		Dimensions In Inches	
	Min	Max	Min	Max
A	0.900	1.150	0.035	0.045
A1	0.000	0.100	0.000	0.004
A2	0.900	1.050	0.035	0.041
b	0.300	0.500	0.012	0.020
c	0.080	0.150	0.003	0.006
D	2.800	3.000	0.110	0.118
E	1.200	1.400	0.047	0.055
E1	2.250	2.550	0.089	0.100
e	0.950 TYP		0.037 TYP	
e1	1.800	2.000	0.071	0.079
L	0.550 REF		0.022 REF	
L1	0.300	0.500	0.012	0.020
θ	0°	8°	0°	8°

SOT-23 Suggested Pad Layout

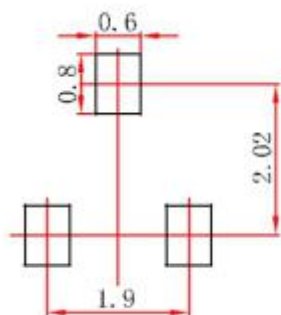

Note:

1. Controlling dimension: in millimeters.
2. General tolerance: $\pm 0.05\text{mm}$.
3. The pad layout is for reference purposes only.